



MTS DuraGlide® 201 Hydraulic Actuators

Precise actuation for testing applications

THE NEED TO TEST FASTER, WITH HIGHER LOADS, GREATER FIDELITY AND INCREASED UPTIME, HAS PUT TOUGHER DEMANDS ON ACTUATORS. TO MEET THESE NEW REQUIREMENTS, THE NEXT GENERATION OF MTS ACTUATION IS LONGER LASTING AND MORE PRECISE THAN EVER BEFORE.



The Right Actuator

MTS actuators are designed to meet the unique precision and dependability requirements of testing. Our engineers use proprietary materials and processes to minimize friction, helping to maximize reliability, wear resistance and energy efficiency. The MTS DuraGlide 201 Hydraulic Actuator uses the latest technology to create our best single-ended actuator yet.

Improved Data Accuracy

These high-fidelity actuators save time by producing statistically significant results in fewer batches. In a closed-loop system, fidelity is only as good as the weakest link, and a poor performing actuator will add distortion and measurement uncertainty into the system. To maximize performance and produce more accurate results, the MTS DuraGlide 201 actuator incorporates proprietary seal and bearing designs that reduce friction.

Longer Performance Life

The low-friction design uses only 1% of rated load, resulting in smooth operation that reduces wear and extends operating life. The MTS DuraGlide 201 Actuator is also validated through physical testing to more than 100% of rated load, providing dependable performance for longer life. Another way to extend actuator life is to choose the optional SureCoat® Rod Finishing Technology to increase service life by 10x over the previous generation actuator.

More Standard Options

With three standard rod configurations and one of the widest ranges of stroke lengths, it is easy to find the appropriate solution for your test applications. There is no need to compromise on size or features—get exactly what you need. These fatigue-rated, single-ended actuators are ideal for everything from basic testing to high-performance applications.



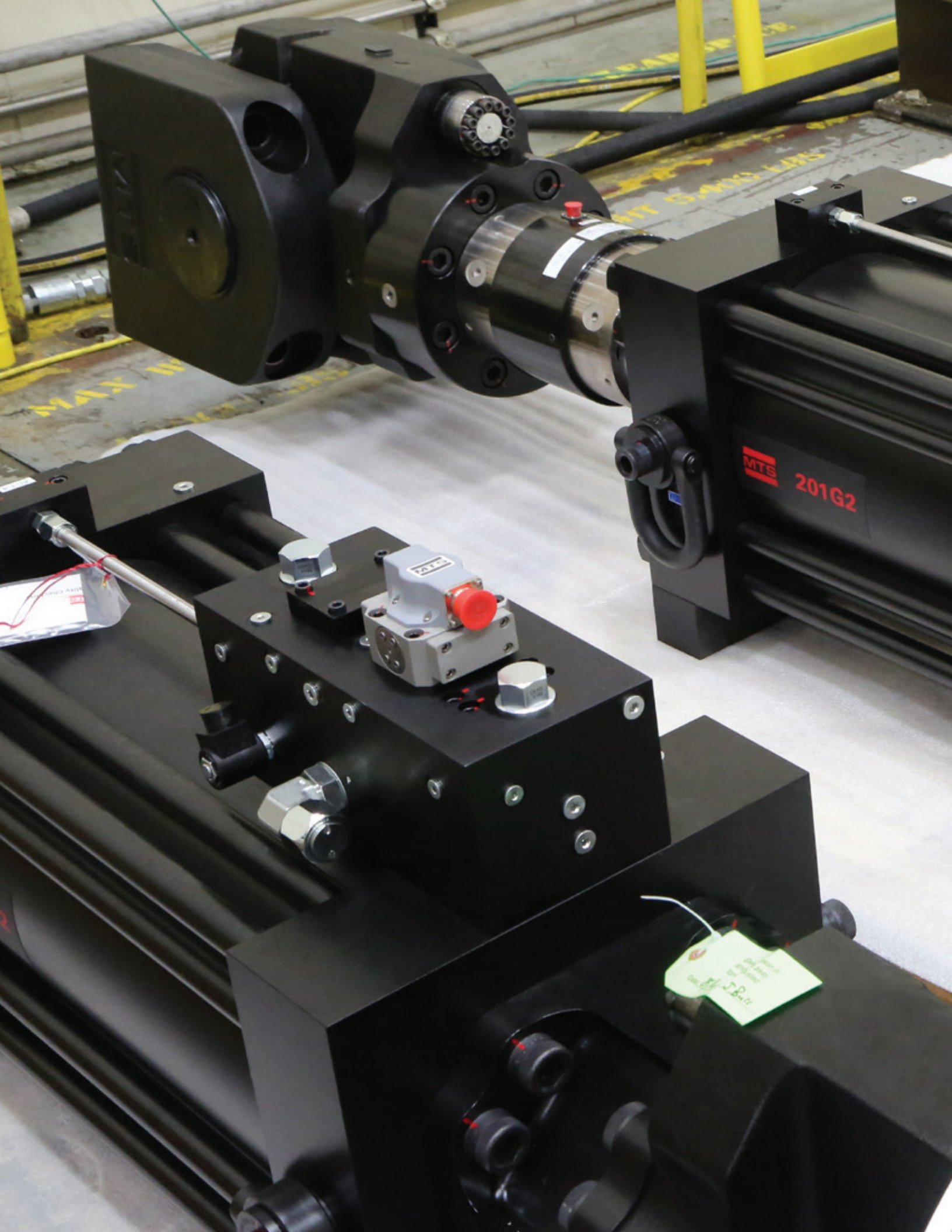

Difference in the Details

Advanced design characteristics make MTS actuators the preferred choice for hydraulic force generation around the world. With hundreds of standard configurations and optional life-extending features, these actuators can support a full array of test applications.

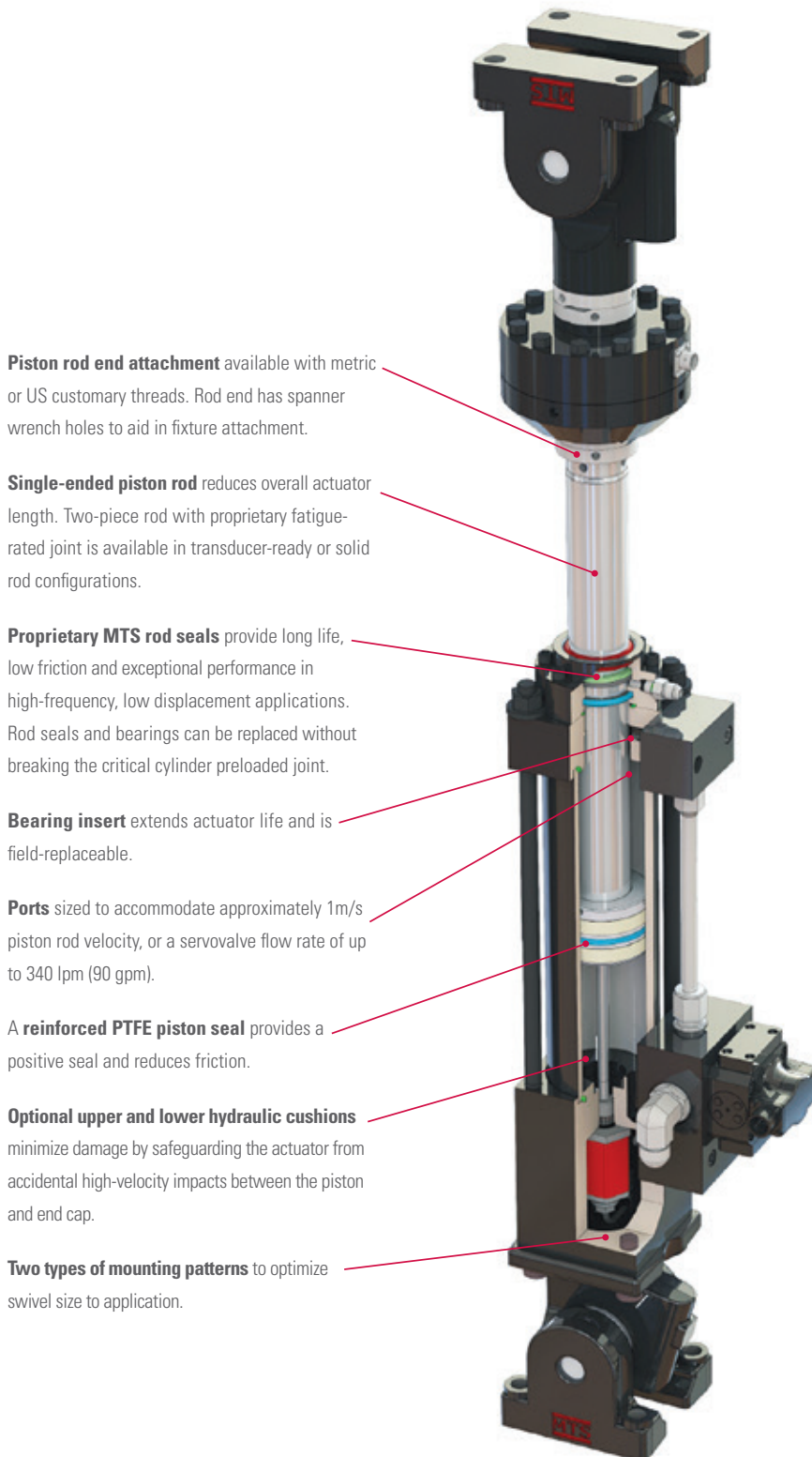

Piston rod end attachment available with metric or US customary threads. Rod end has spanner wrench holes to aid in fixture attachment.

Single-ended piston rod reduces overall actuator length. Two-piece rod with proprietary fatigue-rated joint is available in transducer-ready or solid rod configurations.

Proprietary MTS rod seals provide long life, low friction and exceptional performance in high-frequency, low displacement applications. Rod seals and bearings can be replaced without breaking the critical cylinder preloaded joint.

Bearing insert extends actuator life and is field-replaceable.

Ports sized to accommodate approximately 1m/s piston rod velocity, or a servovalve flow rate of up to 340 lpm (90 gpm).

A **reinforced PTFE piston seal** provides a positive seal and reduces friction.

Optional upper and lower hydraulic cushions minimize damage by safeguarding the actuator from accidental high-velocity impacts between the piston and end cap.

Two types of mounting patterns to optimize swivel size to application.

KEY FEATURES

- » Available with or without displacement transducer to meet specific application needs
- » Low-friction seals comprise only 1% of rated load for energy-efficient operation
- » Optional hydraulic cushions to protect the actuator from the effects of high-speed or high-inertial impacts
- » Optional MTS SureCoat Rod Finishing Technology to maximize performance and increase actuator life

Create Your New Actuator

This step-by-step outline of the configuration process will help you choose the best actuator for your application.

Cylinder Configuration

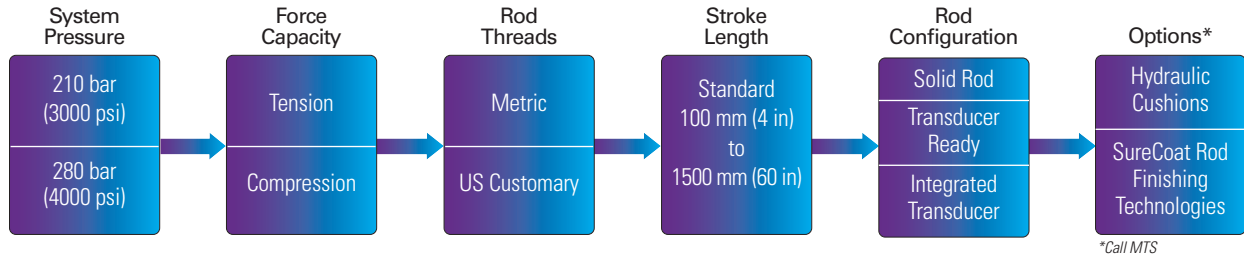

Actuator Configuration

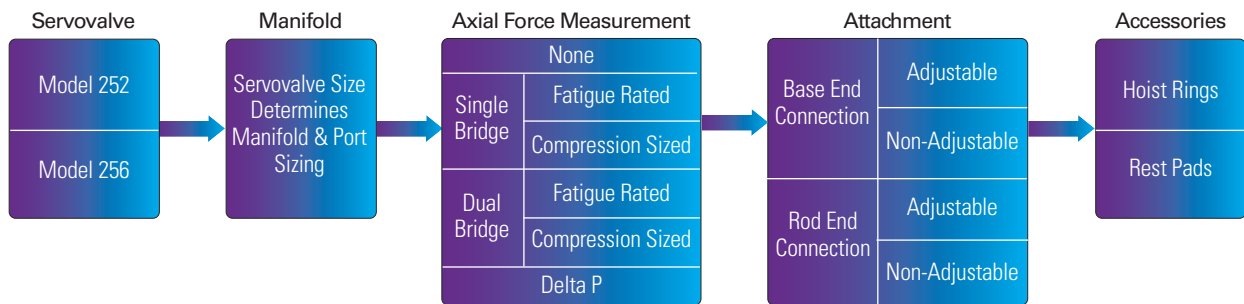

201 Actuator Specifications

Model	Rod Diameter		21 MPa (3000 psi)						28 MPa (4000 psi)						Rod Threads	
			Bore		Tension		Compression		Bore		Tension		Compression			
	mm	in	mm	in	kN	kip	kN	kip	mm	in	kN	kip	kN	kip	Metric	US Customary
201.10	25.4	1.00	34.9	1.38	9.0	2	19	4	31.8	1.25	7.7	2	21	5	M12x1.25	1/2"-20
201.11	34.9	1.38	47.6	1.88	16	4	36	8	44.5	1.75	16	4	42	9	M12x1.25	1/2"-20
201.17	44.5	1.75	63.5	2.50	32	7	63	14	57.2	2.25	27	6	69	16	M27x2	1"-14
201.20	50.8	2.00	82.6	3.25	66	15	107	24	76.2	3.00	68	15	123	28	M27x2	1"-14
201.25	63.5	2.50	101.6	4.00	99	22	162	36	95.3	3.75	106	24	192	43	M27x2	1"-14
201.30	76.2	3.00	127.0	5.00	162	36	253	57	114.3	4.50	153	34	276	62	M36x2	1 1/2"-12
201.35	88.9	3.50	152.4	6.00	241	54	365	82	139.7	5.50	245	55	412	93	M36x2	1 1/2"-12
201.40	101.6	4.00	177.8	7.00	290	75	495	112	165.1	6.50	358	80	576	129	M52x2	2"-12
201.45	114.3	4.50	203.2	8.00	443	100	648	146	184.2	7.25	440	99	716	161	M52x2	2"-12
201.50	127.0	5.00	222.3	8.75	522	117	776	174	203.2	8.00	531	119	872	196	M52x2	2"-12
201.60	152.4	6.00	254.0	10.00	648	146	1013	228	228.6	9.00	613	138	1104	248	M76x2	3"-12
201.70	177.8	7.00	304.8	12.00	962	200	1459	328	279.4	11.00	981	221	1649	371	M90x2	3 1/2"-12
201.80	203.2	8.00	355.6	14.00	1337	301	1986	446	323.9	12.75	1343	302	2215	498	M90x2	3 1/2"-12
201.90	228.6	9.00	406.4	16.00	1773	399	2594	583	368.3	14.50	1761	396	2865	644	M125x4	4 1/2"-8

Determine Stroke Length

Stroke Length	
mm	inch
100	4
150	6
200	8
250	10
300	12
350	14
400	16
450	18
500	20
550	22
600	24
650	26
700	28
750	30
800	32
850	34
900	36
950	38
1000	40
1050	42
1100	44
1150	46
1200	48
1250	50
1300	52
1350	54
1400	56
1450	58
1500	60

Select a Rod Configuration

The MTS DuraGlide 201 Actuator is available in three standard rod configurations:

1. Solid Rod
2. Transducer Ready
3. Integrated Displacement Transducer

SOLID ROD

This configuration is a good choice when there is no critical need for displacement measurement. This economical actuator simplifies test system setup because there is no need for additional signal conditioning and cabling.

TRANSDUCER READY

This actuator does not come with a displacement transducer, but includes a space within the rod where one can be added. This configuration is a smart choice when there is no immediate need for displacement, but there may be a need in the future.

INTEGRATED DISPLACEMENT TRANSDUCER

This actuator configuration is the best option for performance-critical applications. The integrated Temposonics® displacement transducer is naturally aligned to the center of the stroke, which will produce the most accurate results.

Cylinder Options

Reduce wear and increase actuator life with these finishing options.

HYDRAULIC CUSHIONS

Although hydraulic cushions will protect the actuator piston from direct contact with the end cap, which will extend the life of any actuator, they are most critical in high-velocity applications. Lessening piston impact on the end cap will help maintain the actuator performance for years to come.

MTS SURECOAT ROD FINISHING TECHNOLOGY

MTS SureCoat Rod Finishing Technology increases actuator life expectancy by 10x over actuators with conventionally chrome-plated rods. The rod surface coating and proprietary surface-finishing processes reduce rod banding and unloaded rod chatter as well.

Actuators with MTS SureCoat technology experience less of the distortion that can lead to measurement uncertainty, and they save time by producing statistically significant results in fewer batches and at higher operating frequencies. This technology also helps extend seal life, which improves consistency of testing results and reduces the time needed to complete your test profiles.

This technology benefits all actuators, but is especially relevant for high-cyclic applications or high-contaminant environments where actuator wear can be accelerated.



Cylinder Interfaces

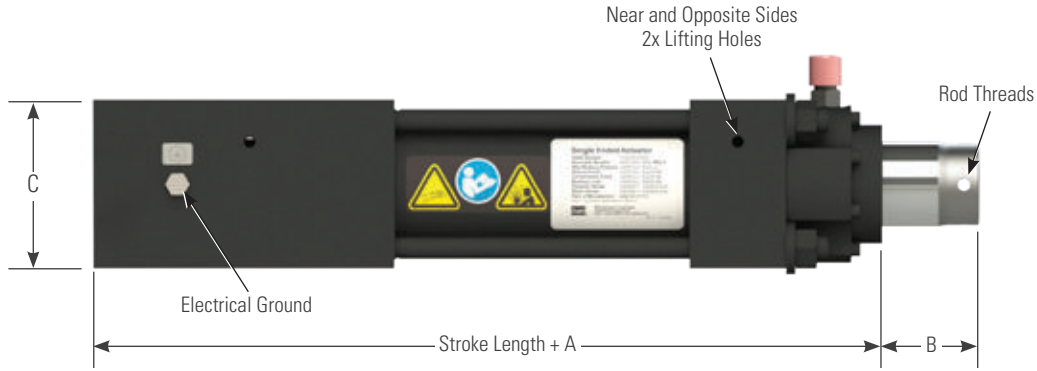

201 Cylinder Dimensions

Model	Stroke Options*				Transducer Ready		Solid Rod		Rod Extension Fully Retracted (B)		Rear End Cap (C)		Rear End Cap Mounting Pattern	
	Minimum		Maximum		Cylinder Body Length (A)		Cylinder Body Length (A)						Primary	Secondary***
	mm	in	mm	in	mm	in	mm	in	mm	in	mm	in		
201.10	100	4	1000	40**	304.8	12.00	228.6	9.00	25.4	1.00	76.2	3.00	Type 1, 249XB.M25	
201.11	100	4	1500	60**	314.2	12.37	238.0	9.37	50.8	2.00	82.6	3.25	Type 1, 249XB.M25	
201.17	100	4	1500	60**	314.2	12.37	238.0	9.37	50.8	2.00	88.9	3.50	Type 1, 249XB.M25	
201.20	100	4	1500	60**	314.2	12.37	238.0	9.37	50.8	2.00	114.3	4.50	Type 1, 249XB.M70	
201.25	100	4	1500	60**	263.4	10.37	238.0	9.37	50.8	2.00	127.0	5.00	Type 1, 249XB.M160	
201.30	100	4	1500	60	286.3	11.27	286.3	11.27	50.8	2.00	165.1	6.50	Type 1, 249XB.M160	
201.35	100	4	1500	60	305.6	12.03	286.3	11.27	50.8	2.00	190.5	7.50	Type 1, 249XB.M340	Type 1, 249XB.M160
201.40	100	4	1500	60	330.2	13.00	-	-	50.8	2.00	225.0	8.86	Type 1, 249XB.M340	
201.45	100	4	1500	60	359.4	14.15	-	-	50.8	2.00	241.3	9.50	Type 2, 249XB.M500	Type 1, 249XB.M340
201.50	100	4	1500	60	391.2	15.40	-	-	50.8	2.00	292.1	11.50	Type 2, 249XB.M500	
201.60	100	4	1500	60	410.2	16.15	-	-	50.8	2.00	355.6	14.00	Type 2, 249XB.M1000	
201.70	100	4	1500	60	475.5	18.72	-	-	50.8	2.00	406.4	16.00	Type 2, 249XB.M1000	
201.80	100	4	1500	60	499.1	19.65	-	-	50.8	2.00	457.2	18.00	Type 2, 249XB.M1750	Type 2, 249XB.M1000
201.90	100	4	1500	60	537.7	21.17	-	-	50.8	2.00	577.9	22.75	Type 2, 249XB.M1750	

*Standard stroke available in increments of 50 mm (2 in). Custom orders can be built up to 2550 mm (100 in) on select models.

**Reduced compression force rating to prevent buckling may exist on long stroke cylinders, contact MTS for more information.

***For static applications, contact MTS for more information.

Type 1	T		U		Thread
	mm	in	mm	in	
249B.M25	31.43	1.237	31.43	1.237	3/8-16 UNC ∇ .75
249B.M70	44.90	1.768	44.90	1.768	5/8-11 UNC ∇ 1.25
249B.M160	44.90	1.768	44.90	1.768	5/8-11 UNC ∇ 1.25
249B.M340	67.64	2.663	67.64	2.663	7/8-11 UNC ∇ 1.44

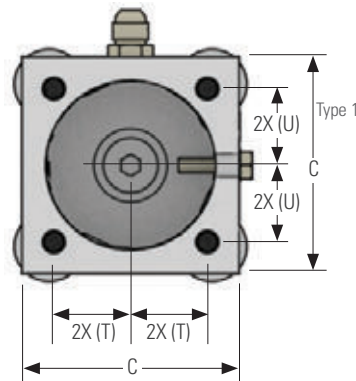

Type 2	V		X		Y		Z		Thread
	mm	in	mm	in	mm	in	mm	in	
249B.M500	71.88	2.830	104.65	4.120	71.88	2.830	104.65	4.120	7/8-9 UNC ∇ 1.44
249B.M1000	81.58	3.212	122.07	4.806	81.58	3.212	122.07	4.806	1-8 UNC ∇ 1.75
249B.M1750	131.73	5.186	174.37	6.865	76.72	3.021	137.61	5.418	1 1/4-7 UNC ∇ 2.00

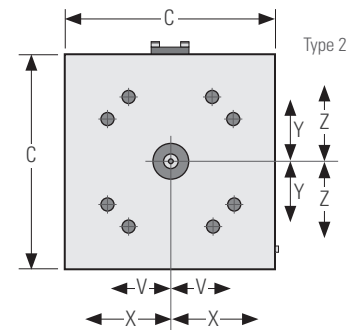

201.10 – 201.17

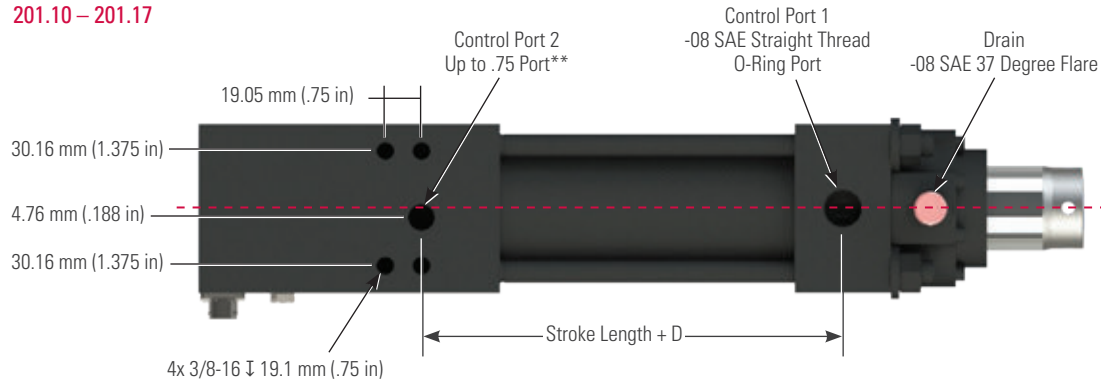

201.20 – 201.90

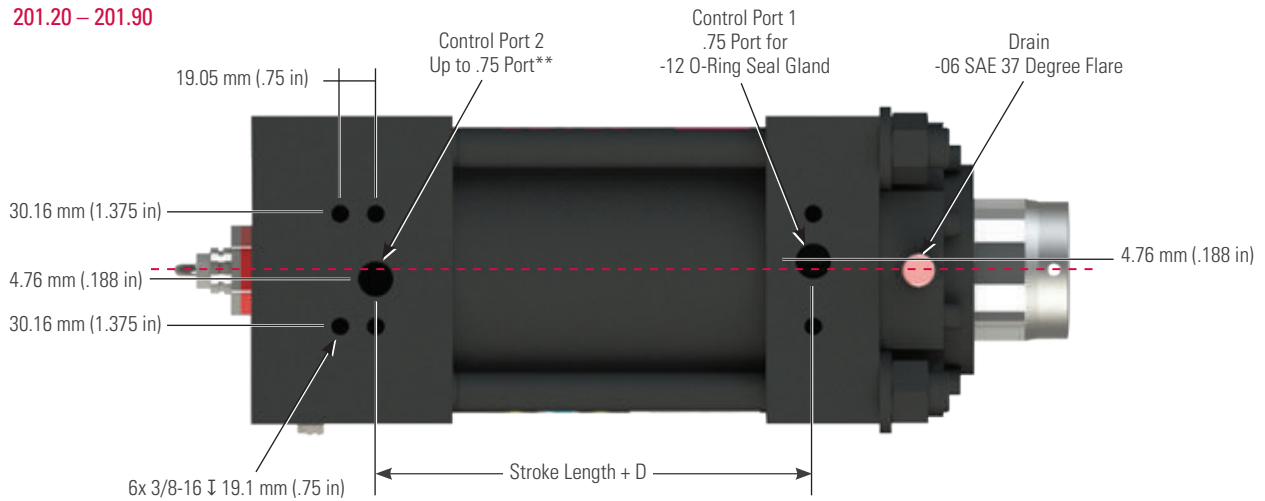

201 Cylinder Manifold Porting Dimensions			
Model	Hydraulic Port Spacing Adder (D)		Maximum Recommended MTS Servo Valve Size*
	mm	in	
201.10	117.5	4.63	252.23
201.11	120.7	4.75	252.24
201.17	120.7	4.75	Dual 252.24
201.20	120.7	4.75	Dual 252.26
201.25	120.7	4.75	256.05
201.30	133.4	5.25	256.09
201.35	133.4	5.25	256.09
201.40	161.9	6.38	256.09
201.45	161.9	6.38	256.09
201.50	161.9	6.38	256.09
201.60	193.7	7.63	256.09
201.70	209.6	8.25	256.09
201.80	209.6	8.25	256.09
201.90	209.6	8.25	256.09

*Maximum valve size could result in cylinder damage if a maximum piston velocity end cap strike occurs. Attached mass and piston velocity need to be considered. MTS offers Hydraulic Cushions to help absorb impact energy. Contact MTS for additional information.

**Interfaces with the face seal gland in the manifold with a .75 port.

Putting It All Together

Durable Components

Choose from a full assortment of complementary products and components for use with your MTS hydraulic actuators. All these options are engineered to improve the quality and repeatability of your test results.

Complete the Assembly

SWIVELS

MTS Series 249 and 249N swivels provide unmatched quality and easy integration with MTS actuator assemblies. The base end swivel includes a cavity to contain a Temposonics® linear-position sensor. This design eliminates the need for a spacer plate, increasing overall stiffness.

Series 249 models feature backlash adjustment, which removes as much relative movement as possible between system and jaws, while allowing the needed rotation for tension-compression loading cycles. Series 249N models do not have backlash adjustment and are ideal for non-reversing applications, such as tension-tension or compression-compression loading cycles.

MOUNTING ACCESSORIES

Choose from a variety of mounting methods, including pedestal, clevis and swivel.

SERVOVALVES

Precision-engineered MTS Series 252 and 256 servovalves deliver high-flow, quick-response and low-distortion performance to uphold the fidelity of your test data.

Other Hydraulic Components

CLOSE-COUPLED ACCUMULATORS

Accumulators provide the stored energy required to meet peak flow demand in a timely manner.

HYDRAULIC SERVICE MANIFOLDS (HSMs)

MTS HSMs reliably control the distribution of hydraulic flow to test stations.

HYDRAULIC POWER UNITS (HPU)s

MTS SilentFlo™ HPUs provide clean, quiet and energy-efficient hydraulic power supply. They are also extremely compact, so they can be deployed directly in the test lab, without the need for special pump housing facilities.

Global Service and Support

MTS fields one of the largest, most experienced global service, support and consulting staff of any testing solution provider. Our complete lifecycle management portfolio can help you maximize your productivity and uptime, while getting the longest functional life possible from your test equipment.

In addition, we can share integration experience to help you create the optimal hydraulic distribution system for your test lab.

201 Actuator Selection Guide				
201 Actuator				
<p>A complete servoactuator assembly includes the actuator, servovalve, load cell, and swivels. The load cell and rod end swivel require attachment kits for connecting these components to the actuator. Servovalves, load cells, rod end swivels, and attachment kits for an actuator assembly are selected separately.</p>	System Pressure	<input type="checkbox"/> 21 MPa (3000 psi) <input type="checkbox"/> 28 MPa (4000 psi)		
	Rod Thread	<input type="checkbox"/> Metric <input type="checkbox"/> US Customary		
	Capacity <i>(refer to the table on page 6 for 28 MPa/4000 psi)</i>	Tension	Compression	
	<input type="checkbox"/> 201.10	9 kN (2.0 kip)	19 kN (4.0 kip)	
	<input type="checkbox"/> 201.11	17 kN (3.7 kip)	36 kN (8.0 kip)	
	<input type="checkbox"/> 201.17	32 kN (7 kip)	63 kN (14 kip)	
	<input type="checkbox"/> 201.20	66 kN (15 kip)	107 kN (24 kip)	
	<input type="checkbox"/> 201.25	99 kN (22 kip)	162 kN (36 kip)	
	<input type="checkbox"/> 201.30	162 kN (36 kip)	253 kN (57 kip)	
	<input type="checkbox"/> 201.35	240 kN (55 kip)	365 kN (80 kip)	
<input type="checkbox"/> 201.40	290 kN (65 kip)	495 kN (110 kip)		
<input type="checkbox"/> 201.45	445 kN (100 kip)	650 kN (145 kip)		
<input type="checkbox"/> 201.50	522 kN (117 kip)	776 kN (174 kip)		
<input type="checkbox"/> 201.60	650 kN (145 kip)	1015 kN (230 kip)		
<input type="checkbox"/> 201.70	965 kN (215 kip)	1460 kN (330 kip)		
<input type="checkbox"/> 201.80	1340 kN (300 kip)	1985 kN (445 kip)		
<input type="checkbox"/> 201.90	1775 kN (400 kip)	2595 kN (590 kip)		

201 Actuator Selection Guide *(continued)*

201 Actuator

Displacement (stroke length)

- | | | | |
|---|---|--|--|
| <input type="checkbox"/> 100 mm (4 in) | <input type="checkbox"/> 500 mm (20 in) | <input type="checkbox"/> 850 mm (34 in) | <input type="checkbox"/> 1200 mm (48 in) |
| <input type="checkbox"/> 150 mm (6 in) | <input type="checkbox"/> 550 mm (22 in) | <input type="checkbox"/> 900 mm (36 in) | <input type="checkbox"/> 1250 mm (50 in) |
| <input type="checkbox"/> 200 mm (8 in) | <input type="checkbox"/> 600 mm (24 in) | <input type="checkbox"/> 950 mm (38 in) | <input type="checkbox"/> 1300 mm (52 in) |
| <input type="checkbox"/> 250 mm (10 in) | <input type="checkbox"/> 650 mm (26 in) | <input type="checkbox"/> 1000 mm (40 in) | <input type="checkbox"/> 1350 mm (54 in) |
| <input type="checkbox"/> 300 mm (12 in) | <input type="checkbox"/> 700 mm (28 in) | <input type="checkbox"/> 1050 mm (42 in) | <input type="checkbox"/> 1400 mm (56 in) |
| <input type="checkbox"/> 350 mm (14 in) | <input type="checkbox"/> 750 mm (30 in) | <input type="checkbox"/> 1100 mm (44 in) | <input type="checkbox"/> 1450 mm (58 in) |
| <input type="checkbox"/> 400 mm (16 in) | <input type="checkbox"/> 800 mm (32 in) | <input type="checkbox"/> 1150 mm (46 in) | <input type="checkbox"/> 1500 mm (60 in) |
| <input type="checkbox"/> 450 mm (18 in) | | | |

Rod Configuration

- Solid Rod
- Transducer Ready
- Integrated Displacement Transducer

Cylinder Options

- MTS SureCoat Rod Finishing Technology
- Hydraulic Cushions

1st Servovalve

- 252.21 - 3.8 lpm (1 gpm)
- 252.22 - 9.5 lpm (2.5 gpm)
- 252.23 - 18.9 lpm (5 gpm)
- 252.24 - 37.9 lpm (10 gpm)
- 252.25 - 56.8 lpm (15 gpm)
- 252.26 - 62.8 lpm (16.6 gpm)
- 256.05A-01 - 190 lpm (50 gpm) Main, 3.8 lpm (1 gpm) Pilot
- 256.09A-01 - 341 lpm (90 gpm) Main, 3.8 lpm (1 gpm) Pilot
- No Servovalve - No Manifold
- No Servovalve - Single 252.2X Manifold Only
- No Servovalve - Dual 252.2X Manifold Only
- No Servovalve - Single 256.05/09A Manifold Only

2nd Servovalve

- None
- 252.21 - 3.8 lpm (1 gpm)
- 252.22 - 9.5 lpm (2.5 gpm)
- 252.23 - 18.9 lpm (5 gpm)
- 252.24 - 37.9 lpm (10 gpm)
- 252.25 - 56.8 lpm (15 gpm)
- 252.26 - 62.8 lpm (16.6 gpm)
- 252.2X Pressure Rated Cover Plate

Axial Force Measurement

- None
- Single-Bridge
- Dual-Bridge
- Delta P

Base *(*not available for every cylinder size)*

- None
- Pedestal
- Adjustable Swivel Base—Static-Sized*
- Adjustable Swivel Base—Fatigue-Sized
- Adjustable Swivel Base—Compression-Sized*
- Non-Adjustable Swivel Base—Static-Sized*
- Non-Adjustable Swivel Base—Fatigue-Sized
- Non-Adjustable Swivel Base—Compression-Sized*

Rod *(*not available for every cylinder size)*

- None
- Adjustable Swivel Base—Static-Sized*
- Adjustable Swivel Base—Fatigue-Sized
- Adjustable Swivel Base—Compression-Sized*
- Non-Adjustable Swivel Base—Static-Sized*
- Non-Adjustable Swivel Base—Fatigue-Sized
- Non-Adjustable Swivel Base—Compression-Sized*

Regional Business Centers

THE AMERICAS

MTS Systems Corporation

14000 Technology Drive
Eden Prairie, MN 55344-2290

USA

Telephone: 952-937-4000

Toll Free: 800-328-2255

E-mail: info@mts.com

Internet: www.mts.com

EUROPE

MTS Systems France

BAT EXA 16
16/18 rue Eugène Dupuis
94046 Créteil Cedex

France

Telephone: +33-(0)1-58 43 90 00

E-mail: contact.france@mts.com

MTS Systems (Germany) GmbH

Hohentwielsteig 3
14163 Berlin

Germany

Telephone: +49-(0)30 81002-0

E-mail: euroinfo@mts.com

MTS Systems S.R.L. a socio unico

Strada Pianezza 289
10151 Torino

Italy

Telephone: +39-(0)11 45175 11 sel. pass.

E-mail: mtstorino@mts.com

MTS Systems Norden AB

Datavägen 37b
SE-436 32 Askim

Sweden

Telephone: +46-(0)31-68 69 99

E-mail: norden@mts.com

MTS Systems Limited

98 Church Street,
Hunslet,
Leeds
LS102AZ

United Kingdom

Telephone: +44 (0) 113 270 8011

E-mail: mtsuksales@mts.com

ASIA/PACIFIC

MTS Japan Ltd.

Raiden Bldg. 3F 3-22-6,
Ryogoku, Sumida-ku,
Tokyo 130- 0026

Japan

Telephone: +81 3 5638 0850

E-mail: mts-j-info@mts.com

MTS Korea, Inc.

2nd F, Bundang Yemiji Building, 31,
Hwangsaeul-ro 258beon-gil,
Bundang-gu, Seongnam-si,
Gyeonggi-do, 13595

Korea

Telephone: +82-31-728-1600

E-mail: mtsk-info@mts.com

MTS Systems (China) Co., Ltd.

Floor 34, Building B,
New Caohejing International
Business Center,
No.391, Guiping Road,
Xuhui District
Shanghai 200233

P.R.China

Telephone: +021-24151000

Market: +021-24151111

Sales: +021-24151188

Service: +021-24151198

E-mail: MTSC-Info@mts.com

MTS Testing Solutions India Pvt Ltd.

No. 38, Ground Floor, Donata Radiance,
1st Cross, Tavarekere Main Road,
DRC Post, Krishna Nagar Industrial Layout,
Kormangala, Bangalore – 560 029

India

Telephone: + 91 80 46254100

Email: mts.india@mts.com



MTS Systems Corporation

14000 Technology Drive
Eden Prairie, MN 55344-2290 USA

ISO 9001 Certified QMS
<http://www.mts.com>

MTS, Temposonics, DuraGlide and SureCoat are registered trademarks and SilentFlo is a trademark of MTS Systems Corporation in the United States. These trademarks may be protected in other countries. RTM No. 211177.

© 2023 MTS Systems Corporation
100-395-058b Hydraulic Actuators 201 • Printed in U.S.A. • 08/23