

MTS DuraGlide® Hydraulic Actuators

Engineered for performance, longevity and efficiency

APPLYING UNMATCHED ENGINEERING AND TEST TECHNOLOGY
EXPERTISE, MTS OFFERS A COMPLETE FAMILY OF HIGHLY RELIABLE,
DURABLE AND ENERGY-EFFICIENT **HYDRAULIC ACTUATORS**,
DESIGNED SPECIFICALLY TO MEET TESTING DEMANDS.



High-performance, fatigue-rated actuators optimized for testing

Servoactuator performance can have a dramatic influence on the accuracy of your test data and the repeatability of your testing. That is why more test professionals insist on running their tests with MTS DuraGlide Hydraulic Actuators.

Every day around the world, test engineers use MTS linear and rotary actuators to address their most demanding material, structural fatigue and component testing requirements. These actuators enable them to measure everything from high-dynamic time histories to pseudo-static creep of highly brittle materials, and are capable of managing the smallest or most massive forces.

MTS actuators are optimized to meet the unique precision and dependability requirements of testing. Our engineers use proprietary materials and processes to minimize friction, helping to maximize reliability, wear resistance and energy efficiency. All MTS actuators are fatigue-rated for years of dependable operation, even in the most demanding applications, and feature fault-tolerant designs to sustain high levels of reliability and uptime over the long term.

Test professionals also depend on MTS to help them integrate safe, quiet, reliable and energy-efficient hydraulic distribution systems, based on their unique needs and facilities configuration.



Performance

A disciplined combination of extensive engineering, top-quality parts and meticulous manufacturing makes it possible for MTS to deliver unmatched actuator performance. Our actuators deliver exceptional fidelity over the full range of motion, along with a superior ability to apply and reconcile multiaxial forces. You can rely upon these built-to-last, fault-tolerant designs to perform, test after test and year after year.

Reliability

All MTS hydraulic actuators feature fatigue-rated designs, which means that they are built to exceed their rated loads for millions of cycles. Put another way, structural failure has essentially been engineered out of the picture. You can be confident in superior actuator performance over a long functional life, maximizing your uptime and minimizing your cost of ownership. Proactive remanufacturing programs and fluid care options help to further extend actuator longevity.

Energy Efficiency

MTS actuators are engineered to provide maximum performance while introducing the minimal amount of friction into the test system, reducing internal flow losses and heat produced, thus requiring less energy to operate. Minimizing drain flow eliminates the need to use scavenge pumps that negatively aerate oil, further reducing the required energy budget.

When you partner with MTS, you tap into a deep reservoir of system integration expertise that can help create the most efficient overall system design possible.

Why all actuators are not created equal

There are many hydraulic actuators in the market, but there are very few that are designed for delivering fidelity in force and motion. Many test labs managers are pressured to use a lower quality actuator to save costs. This compromise of quality to gain a lower acquisition cost is often far more expensive in the long term. When using actuators not specifically designed for testing applications, problems manifest quickly in higher operating costs, lower attainable top frequencies due to distortion, less fault-tolerance to side-loading and buckling, more leaking due to the number of cycles required for fatigue testing and ultimately a much lower overall life expectancy, requiring additional replacement costs. With an MTS hydraulic actuator, you will easily recover any differences in acquisition cost through increased reliability, uptime and energy savings.



Difference in the Details

Advanced design characteristics make MTS hydraulic actuators the preferred choice for dynamic force generation around the world.

MTS SureCoat® Rod Finishing Technology* increases rod service life by 10x over hard chrome-plated rods.

A **piston rod end with replaceable, hardened-steel insert** allows you to quickly replace damaged threads and switch between metric and US customary components.

An **integral bonded bearing design** bonds high-capacity polymer piston rod bearings directly to the end cap, providing high side load tolerance and excellent resistance to galling and seizure. Optional hydrostatic pressure-centering bearings can support continuous high-speed operation under heavy side loads.

A **one-piece, double-ended piston rod design** eliminates compromises caused by unequal tension and compression piston areas. MTS thermal spray-coated rods* increase rod service life by 10x over conventional hard chrome-plated rods.

Large ports accept servovalve flow rates up to 340 lpm (90 gpm), and a **variety of servovalve mounting options** let you configure precisely the performance level you want.

A **reinforced PTFE piston seal** provides a positive seal and reduces friction.

Upper and lower hydraulic cushions safeguard the actuator from accidental high-velocity impacts between the piston rod and end cap.

Proprietary MTS rod seals provide long life, low friction and exceptional performance in high-frequency, low-displacement applications.

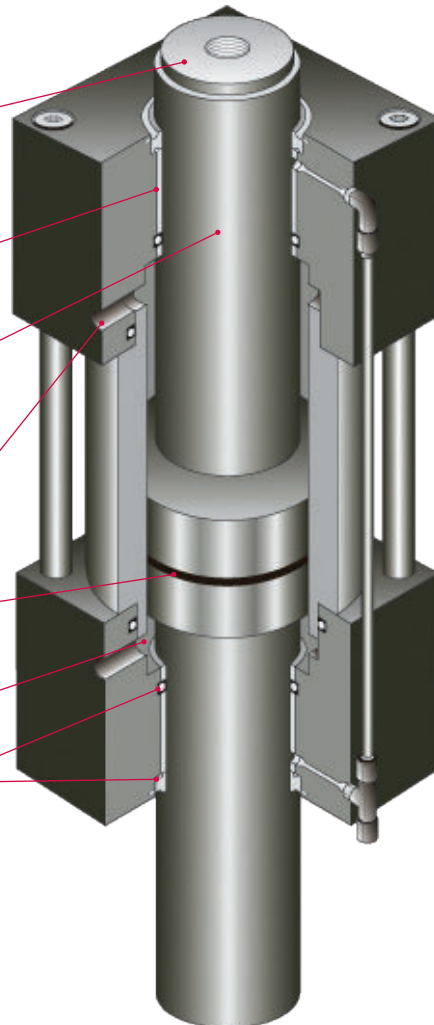

*Standard on 244G2 actuators; optional on 201G2 actuators.

Find the ideal actuator for your needs

Choose from a broad selection of fatigue-rated MTS hydraulic actuators to support your mechanical testing requirements. Our offering ranges from Series 244 Actuators for precise control of high-frequency motions and forces, to the Series 201 Actuator that provides an economical solution for static or low-frequency testing, to heavy-duty MTS rotary actuators that deliver reliable torque generation.

MTS Actuator	Ideal for:	Piston design	Force capacity (Varies by model)	Features & Benefits
Series 244 	<ul style="list-style-type: none"> » Dynamic component fatigue testing » Structural fatigue testing » Vehicle durability testing 	Double-ended	15 kN – 1000 kN (3.3 kip – 220 kip)	<ul style="list-style-type: none"> » Superior reliability and versatility for dynamic force generation » MTS SureCoat Rod Finishing Technology for 10x longer life than hard chrome-plated rods » Standard options for Temposonics® linear transducers or traditional/conventional LVDTs » Proprietary MTS seal and bearing designs for superior performance and long life » MTS-exclusive direct-bonded polymer bearings reduce friction and heat » Hydraulic cushions protect end cap
Series 201 	<ul style="list-style-type: none"> » Aerospace structural testing » Large-force, seismic test systems that require long stroke at lower velocities 	Single-ended	Tension 32 kN – 1775 kN (7.0 kip – 400 kip) Compression 63 kN – 2595 kN (14.0 kip – 590 kip)	<ul style="list-style-type: none"> » Economical solution for superior closed-loop, servo-controlled performance » Fatigue-rated tie rods, bolted connections and polymer bearings improve reliability and wear-resistance » Low-friction seals comprise only 1% of rated load for energy-efficient operation » Standard options for hydraulic cushions » Optional MTS SureCoat Rod Finishing Technology for longer life
Series 242 	<ul style="list-style-type: none"> » Component fatigue testing » Structural resonance searching » Modal analysis 	Double-ended	2.7 kN – 14.7 kN (0.6 kip – 3.3 kip)	<ul style="list-style-type: none"> » Compatible with a broad range of MTS servovalves » Nonmetallic bearings provide high side-loading capabilities and eliminate bearing-to-rod galling failures » Low-pressure piston rod seals ensure low-friction operation and minimize fluid leakage
Series 248 	<ul style="list-style-type: none"> » Vehicle vibrational analysis on the MTS Model 320 Tire-Coupled Test System » High-frequency elastomer testing 	Double-ended	10 kN – 250 kN (2.2 kip – 55.0 kip)	<ul style="list-style-type: none"> » Hydrostatic pressure-centering bearings support continuous high-speed operation under heavy side loads » Large-diameter single-piece chrome-plated piston rod provides excellent strength and lateral stiffness. » Hydraulic cushions protect end cap during full-stroke, high-frequency operation
Series 215 (rotary) 	<ul style="list-style-type: none"> » Testing materials, axles, couplings, driveshafts, and other components involving rotational movement 		Dynamic torque ratings from 226 N-m – 11,300 N-m (2000 lbf-in – 100,000 lbf-in)	<ul style="list-style-type: none"> » Reliable, heavy-duty torque generation in a closed-loop servohydraulic testing environment » Heavy-duty roller bearings withstand high radial loads and facilitate low friction and long life » Precision-machined, non-metallic coated roller design reduces friction and eliminates backlash » Equal working area for clockwise and counter-clockwise rotation provides balanced control
Series 216 (rotary) 	<ul style="list-style-type: none"> » Testing materials, axles, couplings, driveshafts, and other components involving rotational movement » Provides more torque than the Series 215 rotary actuators, while maintaining incredible control fidelity 		Dynamic torque ratings from 22,597 N-m – 82,479 N-m (200,000 lbf-in – 730,000 lbf-in)	<ul style="list-style-type: none"> » Reliable, heavy-duty, high-torque generation in a closed-loop servohydraulic testing environment » Heavy-duty bearings and double-vane rotor design accommodate significant radial and axial loads » Precision chamber and rotor design ensures zero actuator backlash during torque reversals » Equal working area for clockwise and counter-clockwise rotation provides balanced control

Keys to faster fatigue testing

Low Distortion Actuator Assemblies

In a closed loop testing system, you can only run as fast as your weakest link, or in this case, as fast as your most distorted actuator. Low distortion actuator assemblies let you run tests faster.

Common Issues – Signal Distortion & Noise

Distortion or noise in the data causes errors in the resulting mathematical calculations. Even a small amount of distortion can cause large calculation errors and increased uncertainty of results. Distortion is typically non-repeatable and therefore it is difficult to apply a data correction.

MTS actuators are designed to minimize distortion, and MTS provides solutions for many of the common causes of distortion.

Software Innovations

Recent software innovations have enabled huge improvements in structural testing speed. First, there's Forward Loop Optimization, or FLO, which applies algorithms that automatically condition valve commands before they are sent to the servovalve. When used correctly, it

can make a channel appear more stable. Next, there's Profile Segment Optimization (PSO), which automatically adjusts the transition time as a test runs to make the transition as fast as possible, while still staying within user-defined error limits.

And now we get to the game changer. MTS has developed a method that compensates for the cross-coupling of actuators through the test article. This feature, referred to as Cross-Coupling Compensation (CCC), fully compensates for the influences of all actuators present without compromising accuracy or introducing additional strains on test articles.

CCC eliminates the need to input cross-coupling information manually and allows the use of unit load cases to provide automated coefficient generation. Our customers have reported improving their test speeds by up to four times after employing CCC.

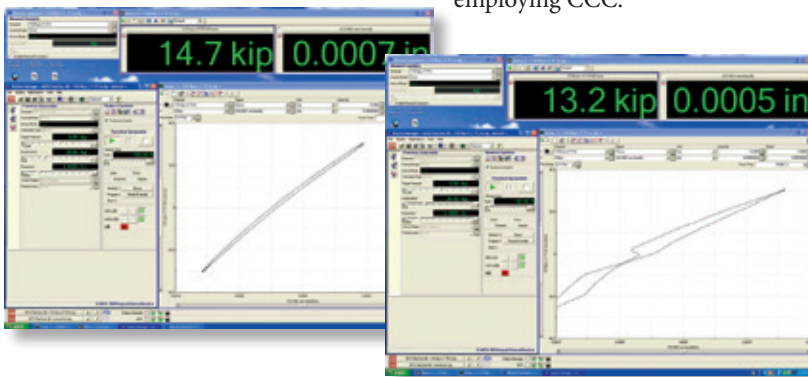

Distortion Cause	MTS Solution
Backlash in bearings, system and specimen resonances	Swivels and spiral washers designed to minimize backlash
Incorrectly mounted transducers	Fully integrated standard options for Temposonics linear transducers or traditional/conventional LVDTs
Incorrectly grounded conditioners	Hydraulic distribution system consulting
Incorrect shielding of cables	Hydraulic distribution system consulting
Electrical noise in the laboratory	Hydraulic distribution system consulting
Stiction of the actuator	Integral bonded bearing design, reinforced PTFE piston seal, proprietary MTS piston rod seals
Instability in the system	Software innovations such as Forward Loop Optimization, Profile Segment Optimization and Cross-Coupling Compensation

Durable Components

Choose from a full assortment of complementary products and components for use with your MTS hydraulic actuators. All these options are engineered to improve the quality and repeatability of your test results.

LINEAR VARIABLE DIFFERENTIAL TRANSFORMERS

MTS 244G2 actuators come with standard LVDTs. Manufactured to strict MTS specifications, these LVDTs produce an analog signal with excellent linearity.

TEMPOSONICS® LINEAR SENSORS

These sensors use the time-based magnetostrictive position sensing principle developed by MTS and are offered as a standard option. Non-contact sensing reduces wear and increases durability and output repeatability. Temposonics displacement achieves ASTM E2309 Class A performance accuracy.

FORCE TRANSDUCERS

Highly accurate MTS force transducers feature a low-profile design for easy system integration.

MOUNTING ACCESSORIES

Choose from a variety of mounting methods, including pedestal, clevis and swivel.

SWIVEL ROD ENDS

This spherical bearing features a patented adjustable preload mechanism to minimize backlash.

SPIRAL WASHERS

These accessories create a backlash-free assembly by fully preloading the connections between actuator, mounting and force transducer.

SERVOVALVES

Precision-engineered MTS servovalves deliver high-flow, quick-response and low-distortion performance to uphold the fidelity of your test data.

PEDESTAL BASE ACTUATOR

Although most applications profit from at least a small degree of pivotal freedom, others require rigid actuator fixturing. Pedestal bases are available for all actuator models to handle these situations. Vibration testing, seismic tables, and horizontal cantilever installations are common applications for pedestal bases. Check with your sales representative for help in determining the effect of sidelading on pedestal base installations.

CLOSE-COUPLED ACCUMULATORS

Accumulators provide the stored energy required to meet peak flow demand in a timely manner.

HYDRAULIC SERVICE MANIFOLDS (HSMs)

MTS HSMs reliably control the distribution of hydraulic flow to test stations.

HYDRAULIC POWER UNITS (HPUs)

MTS SilentFlo™ HPUs provide clean, quiet and energy-efficient hydraulic power supply. They are also extremely compact, so they can be deployed directly in the test lab, without the need for special pump housing facilities.

FROM THE LEADING GLOBAL PROVIDER OF TESTING SOLUTIONS, SERVICE AND SUPPORT

MTS is recognized worldwide for helping people build confidence in the performance of their products. Our high-performance hydraulic actuators play a central role in helping test professionals achieve the highest levels of certainty.

We also field one of the largest, most experienced global service, support and consulting staff of any testing solution provider. Our complete lifecycle management services portfolio can help you maximize your productivity and uptime, while getting the longest functional life possible from your MTS investments.

Since our company's very beginning, we have also been deeply involved in the engineering, fabrication and installation of hydraulic distribution systems for customers worldwide. We can apply sound engineering practices at all stages of design and integration, to provide you with the optimal hydraulic distribution system for your test lab.



Regional Business Centers

THE AMERICAS

MTS Systems Corporation
14000 Technology Drive
Eden Prairie, MN 55344-2290
USA
Telephone: 952-937-4000
Toll Free: 800-328-2255
E-mail: info@mts.com
Internet: www.mts.com

EUROPE

MTS Systems France
BAT EXA 16
16/18 rue Eugène Dupuis
94046 Créteil Cedex
France
Telephone: +33-(0)1-58 43 90 00
E-mail: contact.france@mts.com

MTS Systems (Germany) GmbH
Hohentwielsteig 3
14163 Berlin
Germany
Telephone: +49-(0)30 81002-0
E-mail: euroinfo@mts.com

MTS Systems S.R.L. a socio unico
Strada Pianezza 289
10151 Torino
Italy
Telephone: +39-(0)11 45175 11 sel. pass.
E-mail: mtstorino@mts.com

MTS Systems Norden AB
Datavägen 37b
SE-436 32 Askim
Sweden
Telephone: +46-(0)31-68 69 99
E-mail: norden@mts.com

MTS Systems Limited
98 Church Street,
Hunslet,
Leeds
LS102AZ
United Kingdom
Telephone: +44 (0) 113 270 8011
E-mail: mtsuksales@mts.com

ASIA/PACIFIC

MTS Japan Ltd.
Raider Bldg. 3F 3-22-6,
Ryogoku, Sumida-ku,
Tokyo 130- 0026
Japan
Telephone: +81 3 5638 0850
E-mail: mts-j-info@mts.com

MTS Korea, Inc.
2nd F, Bundang Yemiji Building, 31,
Hwangsaeul-ro 258beon-gil,
Bundang-gu, Seongnam-si,
Gyeonggi-do, 13595
Korea
Telephone: +82-31-728-1600
E-mail: mtsk-info@mts.com

MTS Systems (China) Co., Ltd.
Floor 34, Building B,
New Caohejing International
Business Center,
No.391, Guiping Road,
Xuhui District
Shanghai 200233
P.R.China
Telephone: +021-24151000
Market: +021-24151111
Sales: +021-24151188
Service: +021-24151198
E-mail: MTSC-Info@mts.com

MTS Testing Solutions India Pvt Ltd.
No. 38, Ground Floor, Donata Radiance,
1st Cross, Tavarekere Main Road,
DRC Post, Krishna Nagar Industrial Layout,
Kormangala, Bangalore – 560 029
India
Telephone: + 91 80 46254100
Email: mts.india@mts.com



MTS Systems Corporation
14000 Technology Drive
Eden Prairie, MN 55344-2290 USA

ISO 9001 Certified QMS
<http://www.mts.com>

MTS, Temposonics, DuraGlide and SureCoat are registered trademarks and SilentFlo is a trademark of MTS Systems Corporation in the United States. These trademarks may be protected in other countries. RTM No. 211177.

©2023 MTS Systems Corporation
100-242-956b Hydraulic Actuators • Printed in U.S.A. • 08/23