

Servovalves

Durable, reliable performance for precise servohydraulic control

MTS SERVOVALVES DELIVER THE SPEED, PERFORMANCE AND FIDELITY TEST PROFESSIONALS NEED TO ACHIEVE REPEATABLE, REPRODUCIBLE AND HIGHLY ACCURATE RESULTS IN A WIDE RANGE OF APPLICATIONS. DESIGNED TO TIGHT TOLERANCES FOR EXCEPTIONAL CONTROL, ALL OF THE SERVOVALVES IN OUR PORTFOLIO DELIVER RELIABLE PERFORMANCE AND OUTSTANDING DURABILITY.



The essence of control

High-quality servovalve performance is essential to controlling the forces and motions of mechanical testing. Servovalves are critical to reliable test system performance and are the final control element in most MTS closed-loop systems. As an industry leader in servohydraulic testing, MTS has a deep understanding of the unique and demanding requirements of servovalve operation. The success of our servovalve portfolio extends for decades, spanning an incredible variety of markets and applications.

Today, we continue to apply this experience and expertise as we provide durable, reliable servovalves for a wide range of flow rates and performance curves. With our complete line of servovalves, we can configure combinations that generate the ideal blend of power, finesse and overall performance.

High Durability

MTS servovalves feature rugged designs for long operating life in dynamic applications. Fault-tolerance helps extend operation in the event of errors and preserve the integrity of test data. Also, a high degree of contaminant tolerance gives test teams ample time to diagnose and resolve operating issues before they compromise test results.

Superior Fidelity

Elegantly engineered MTS servovalves allow test professionals to move a million-pound force capacity actuator a few microns or complete fatigue tests that run for billions of cycles – all with exceptional accuracy. Tight tolerances ensure MTS servovalves achieve finesse and produce precise moments, especially at the high end of performance curves.

Extreme Repeatability

Repeatable, reproducible results are critical to test integrity and validity. Because MTS servovalves are designed and manufactured according to stringent specifications, you can expect them to meet or exceed expectations from lab to lab, system to system, and test to test, whether operators are experienced experts or relative newcomers.

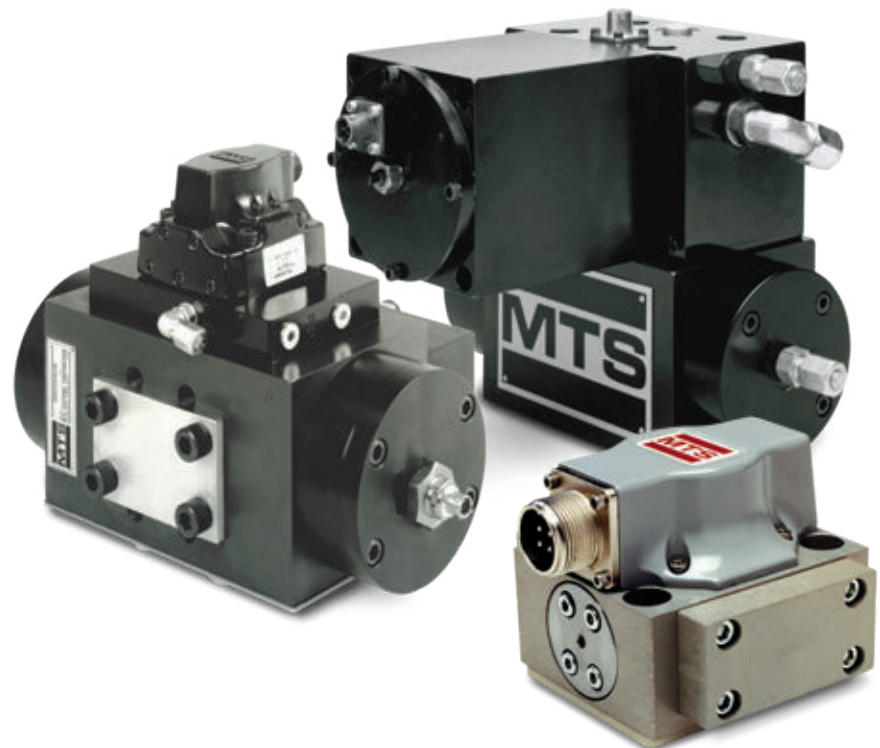

Series 252 Servovalves

MTS Series 252 Servovalves are two-stage, four-way servovalves specifically designed for low to medium flow rates of 3.8 to 227 lpm (1 to 60 gpm*) in high-response servohydraulic systems. Depend on these workhorse components for solid, consistent performance.

** 1/8, 1/4 and 1/2 gpm valves are also available upon request*

Common Applications

Typical applications for Series 252 Servovalves include hydraulic power control and regulation in fatigue test systems, simulators, servohydraulic process controls and industrial controls. Applications that require higher flow rates can be accommodated with two

Series 252 Servovalves connected in parallel, which doubles the flow rating. This dual configuration (which requires a special dual-valve manifold) not only costs less to operate than a larger valve, it offers higher availability and increased response rate in some applications.

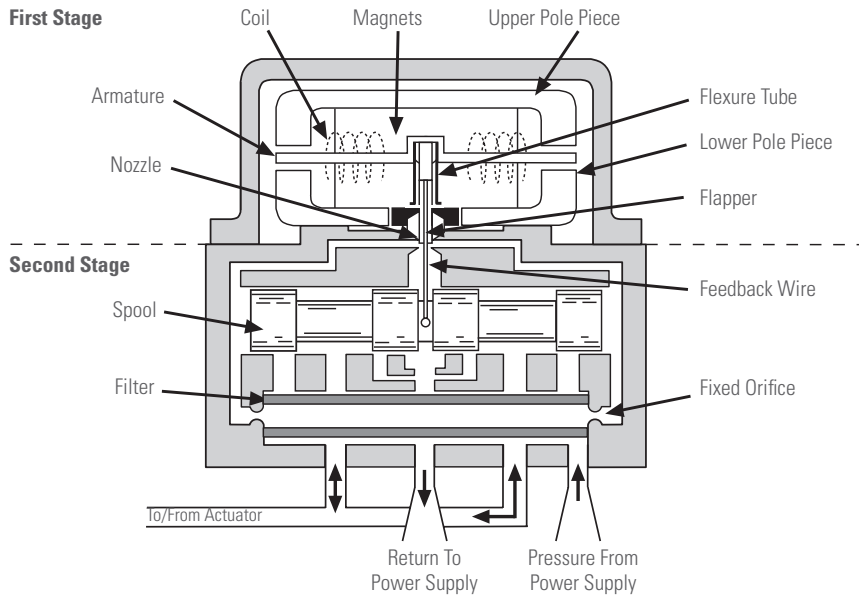

- » Nozzle-flapper design with spool feedback provides positive internal closed-loop flow control
- » Internal filtration protects nozzle orifices from contamination
- » Standard mounting configurations make it simple to change flow ratings
- » Unpeaked response over servo-system frequency range
- » 31 MPa (4500 psi) operating pressure ensures optimal performance and reliability
- » High spool-driving forces (over 100 pounds-force) provide low contamination sensitivity
- » All but 252.36, 252.37, and 252.38 can be configured with a fifth port, which separates pilot pressure from system pressure

Performance

Each Series 252 Servovalve includes a torque motor and two stages of hydraulic power regulation. The torque motor controls the first stage by positioning a flapper that controls hydraulic fluid flow from two nozzles in the first stage. Differential pressure positions the second stage spool, which controls the direction and rate of hydraulic fluid flow to the actuator.

These servovalves incorporate all the advantages of closed-loop control. As the second stage spool reacts, a feedback spring by the spool counters the action of the torque motor and flapper. By the time the spool reaches the commanded position, the motor and flapper are counteracted. Flow from both nozzles is equal and the spool stops. This design ensures precise control of spool position, a high hydraulic driving force on the spool and a high error-force gradient.

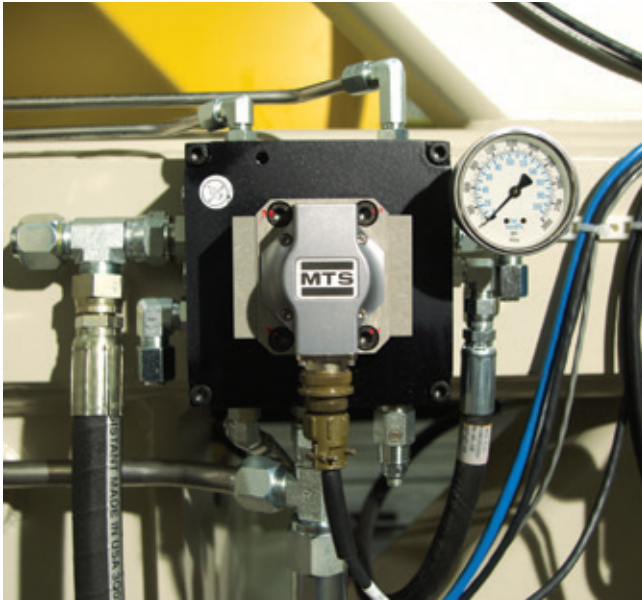

Series 252 Servovalves are ideal for low and medium flow applications.

Typical Performance Characteristics

Model	Full Flow Rating*		90° point at 10% command	Null Flow†	
	L/min	gpm		L/min	gpm
252.21C	4.0	1.0	240 Hz	1.10	0.29
252.22C	9.5	2.5	240 Hz	1.44	0.38
252.23C	19.0	5.0	240 Hz	2.27	0.60
252.24C	38.0	10.0	200 Hz	2.27	0.60
252.25C	57.0	15.0	150 Hz	2.27	0.60
252.31A‡	93.0	25.0	80 Hz	5.56	1.47
252.32A‡	151.0	40.0	60 Hz	5.56	1.47
252.33A‡	227.0	60.0	50 Hz	8.33	2.20
252.36A¹	85.2	22.5	90 Hz	2.0	0.53
252.37A¹	136	36.0	90 Hz	4.0	1.1
252.38A¹	204	54.0	70 Hz	4.0	1.1
252.41A	4.0	1.0	300 Hz	1.10	0.29
252.42A	9.5	2.5	280 Hz	1.44	0.38
252.43A	19.0	5.0	280 Hz	2.27	0.60

* Flow ratings are for 7 MPa (1000 psi) pressure drop across the servovalve. Higher flows are available at higher pressure drops.

† The maximum internal null flow is specified at 21 MPa (3000 psi). The null flow at the first stage is 0.76 L/min (0.20 gpm) for all Series 252 Servovalves.

‡ The 90° point is at 40% command.

¹ The 90° point is at 25% command.

Specifications are subject to change without notice. Contact MTS for verification of specifications critical to your needs.

The flow vs. frequency response curves below show typical servovalve performance with sine wave control and $\pm 100\%$ command.

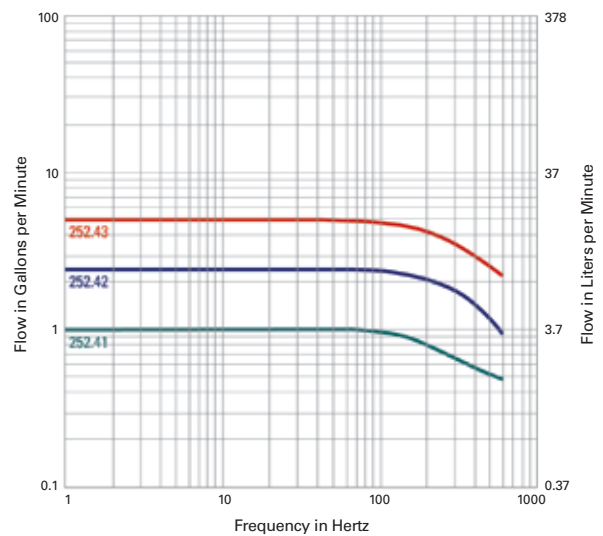
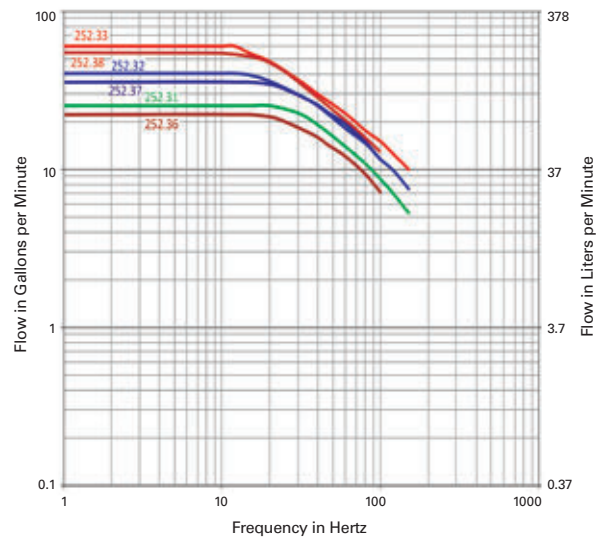
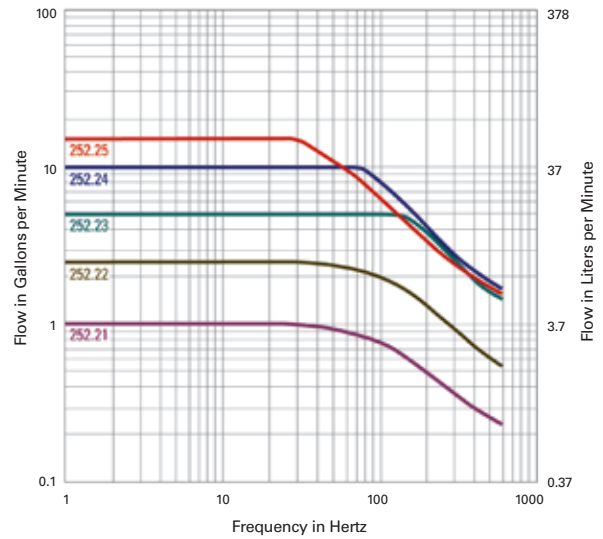

Note: Performance is with 21 MPa (2000 psi) pressure applied and 7 MP (1000 psi) pressure drop across the servovalve.

Series 256 Servovalves

MTS Series 256 Servovalves are electrohydraulic three-stage servovalves consisting of a high-flow, four-way spool valve and a smaller two-stage pilot valve. They are designed and engineered for the critical requirements of high-flow, high-response, closed-loop servohydraulic testing.

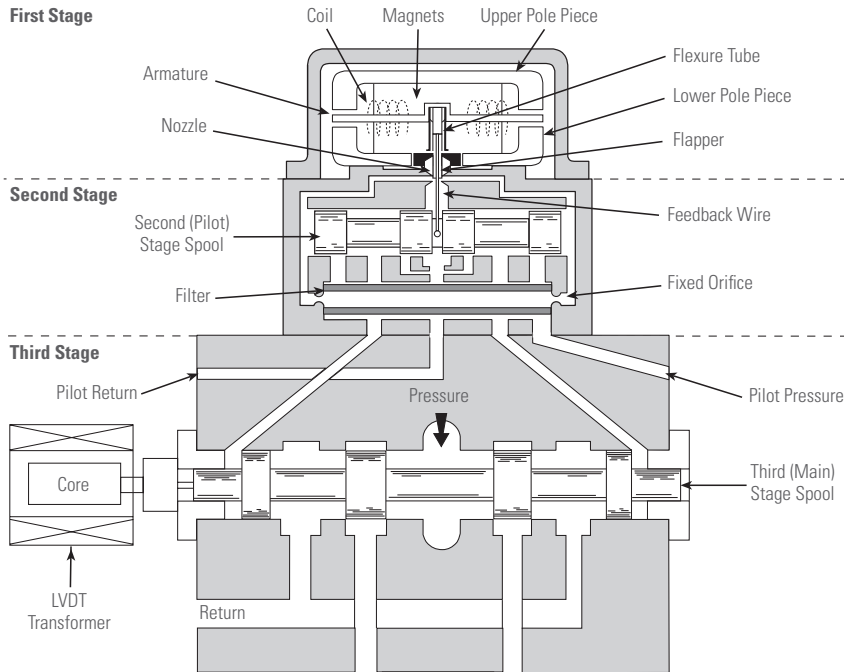

- » 21 MPa (3000 psi) operating pressure ensures optimal performance and reliability
- » Internal filtration protects nozzle orifices from contamination
- » Electronic spool position feedback improves tuning and system performance with three-stage valve drivers
- » Very low current threshold ensures high servovalve control resolution
- » Matched, ground metering edges minimize crossover distortion
- » High spool-driving forces and hardened tool-steel metering edges decrease erosive wear and reduce the risk of spools sticking due to dirty hydraulic fluid

Performance

Series 256 Servovalves use a Series 252 Servovalve to drive a larger spool in a third stage. An internal linear variable differential transformer (LVDT) monitors the third-stage spool position and provides a signal to the servovalve controller on a three-stage valve driver. The valve controller compares the spool position with the DC error signal and alters the control signal to the torque motor in the first stage accordingly. When DC error reaches zero, servo action in the inner loop decreases and both spools return to their null positions, stopping the flow to the actuator.

Common Applications

Typical applications for Series 256 Servovalves include position, load, or velocity control of larger hydraulic actuators in highly dynamic applications, as well as pressure control in a dynamic pressurization system. Some models can be configured with different sizes of pilot stage servovalves for unique performance requirements. Be sure not to exceed performance requirements significantly, because systems can be difficult to control if servovalves are oversized for a specific application.

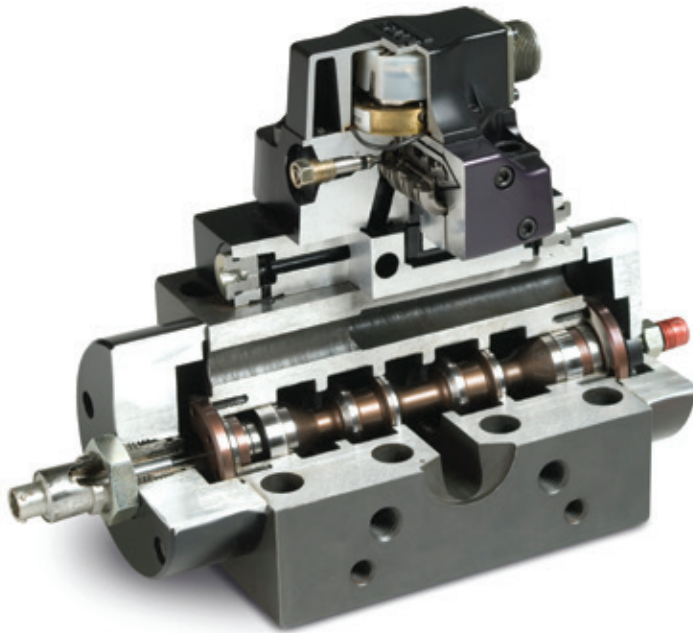

Series 256 Servovalves are engineered for high-flow, high-response applications.

Static Servovalve Performance

Model*	Rated Flow		Nominal Null Flow Gain		Null Pressure Gain (% supply/ % stroke)	Null Flow-Pressure Coefficient		Null Flow	
	L/min	gpm	L/min/% stroke	gpm/% stroke		cm ⁵ /kgf/sec	in. ³ /sec/psi	L/min	gpm
256.04	151	40	4.2	1.1	100	0.28	1.2 x 10 ⁻³	7.0	2.0
256.09	340	90	6.0	1.6	150	0.56	2.4 x 10 ⁻³	13.0	3.5
256.18	680	180	10.6	2.8	200	0.73	3.1 x 10 ⁻³	21.0	5.5
256.25	950	250	16.0	4.2	160	1.38	5.9 x 10 ⁻³	23.0	6.0
256.40	1500	400	29.0	7.7	250	1.61	6.9 x 10 ⁻³	28.0	7.5

Dynamic Servovalve Performance

Model*	Rated Flow ¹		Pilot Flow		Full Flow Frequency ^{2,3} (Hz)	90° Phase Signal ^{3,4} (Hz)	Spool Stroke Rise Time (tr) ³ (milliseconds)	
	L/min	gpm	L/min	gpm			90% open	10% open
256.04X-01	151	40	3.8	1	100	130	3	2.5
256.09X-01	340	90	3.8	1	30	90(A) 165(B)	9	3.5
256.09X-02	340	90	9.5	2.5	60	85(A) 165(B)	4.6	2.5
256.09X-05	340	90	19	5	100	265(B)	3.5	3.5
256.18X-01	680	180	3.8	1	20	120	7.6	3
256.18X-02	680	180	9.5	2.5	47	130	5	2.5
256.18X-03	680	180	19	5	65	110	4.5	2
256.25X-01	950	250	3.8	1	10	90	15	10
256.25X-02	950	250	9.5	2.5	18	125	<10	<10
256.25X-05	950	250	19	5	25	125	8	4
256.40X-01	1500	400	3.8	1	4 ⁵	40 ⁵	65 ⁵	20 ⁵
256.40X-02	1500	400	9.5	2.5	9 ⁵	75 ⁵	26 ⁵	8 ⁵
256.40X-05	1500	400	19	5	12 ⁵	110	13	4
256.40X-10	1500	400	38	10	15 ⁵	110	10	3.5

* All values are typical of Series 256 Servovalves operated at the recommended hydraulic fluid filtration levels.

1 With a 7 MPa (1000 psi) pressure drop across the servovalve.

2 The data is derived from typical Model 256 Servovalves driven with a valve controller with "rate" compensation. A constant sine wave was directed to the valve controller. The amplitude was ± the main-stage, full-stroke, LVDT voltage. The servovalve flow at the higher frequencies depends on many system characteristics that are unrelated to the Model 256 Servovalve (e.g., hydraulic fluid compressibility, supply and return line lengths, actuator characteristics and load or specimen characteristics).

3 Unless otherwise specified, values given in this column are for Model 256.XXA/.XXC Servovalves. Contact MTS for Model 256.XXB/.XXD.

4 At ±10% spool stroke.

5 These are estimated values. All other values are typical.

Series 256 Servovalve Flow Frequency Performance Curves

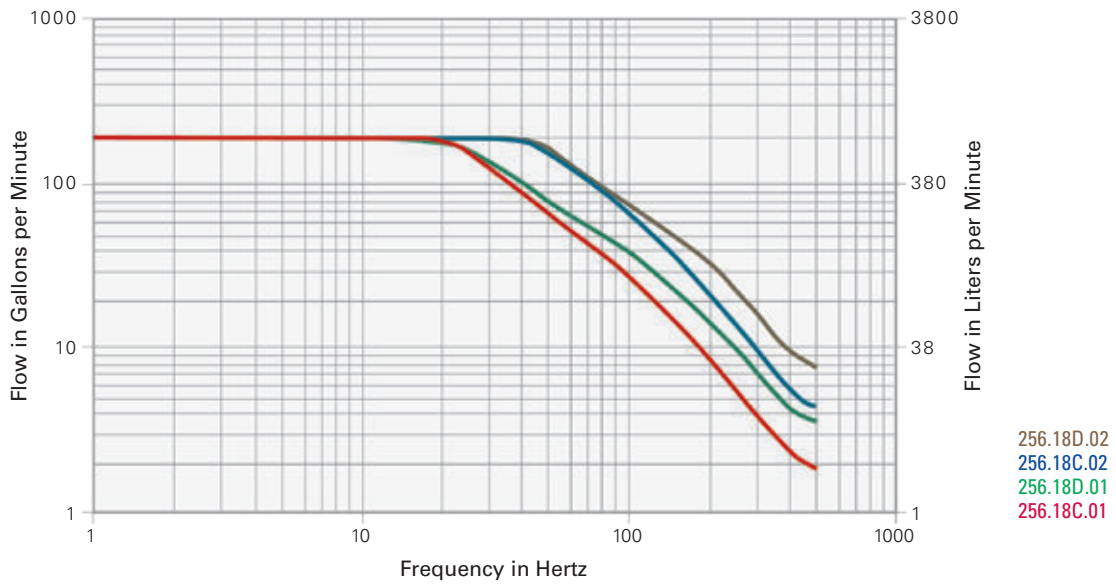
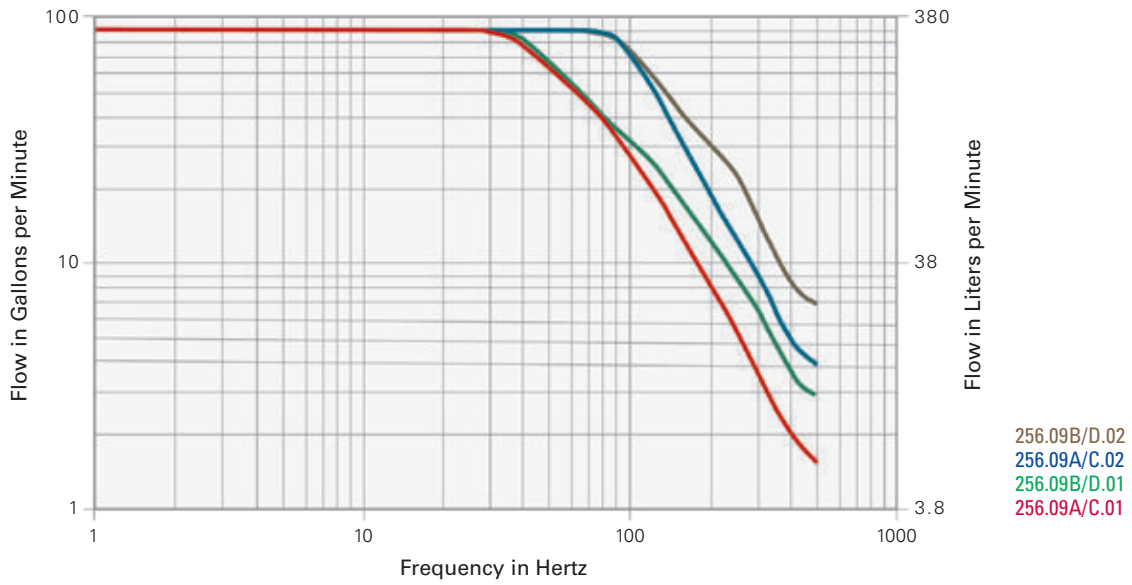
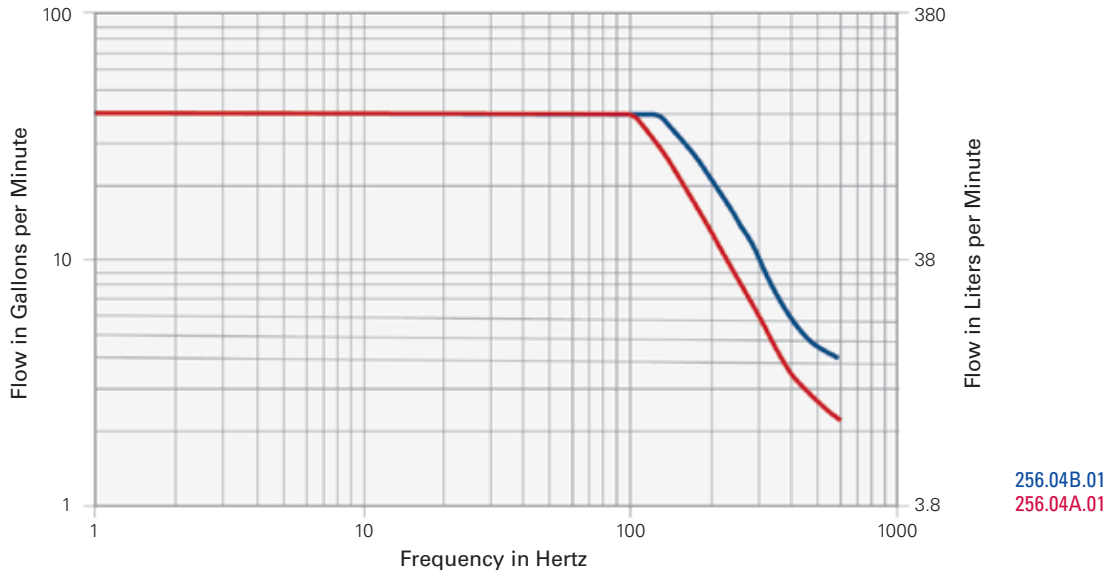

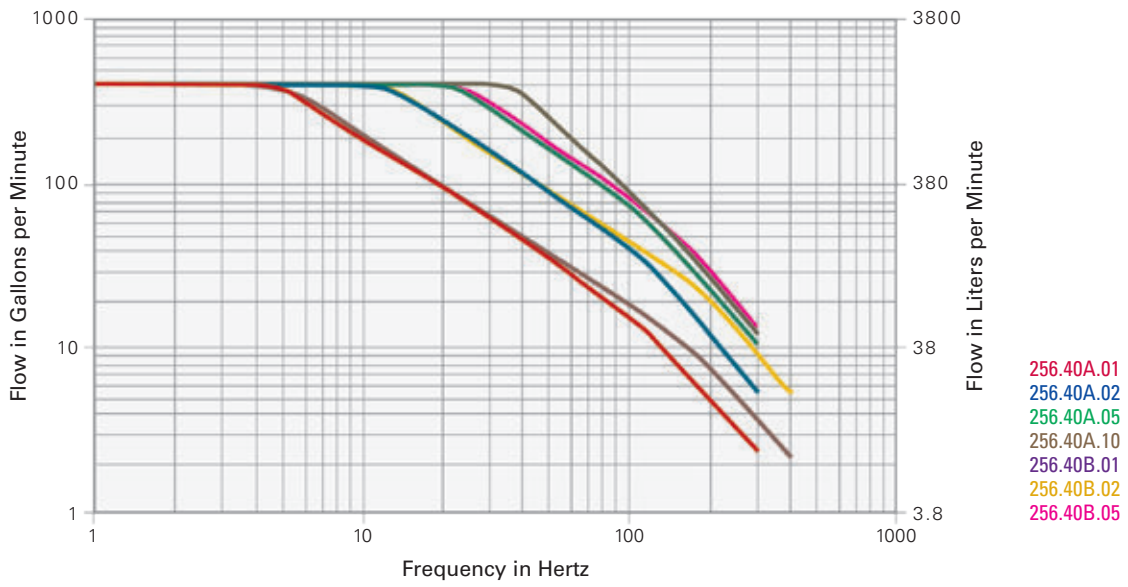
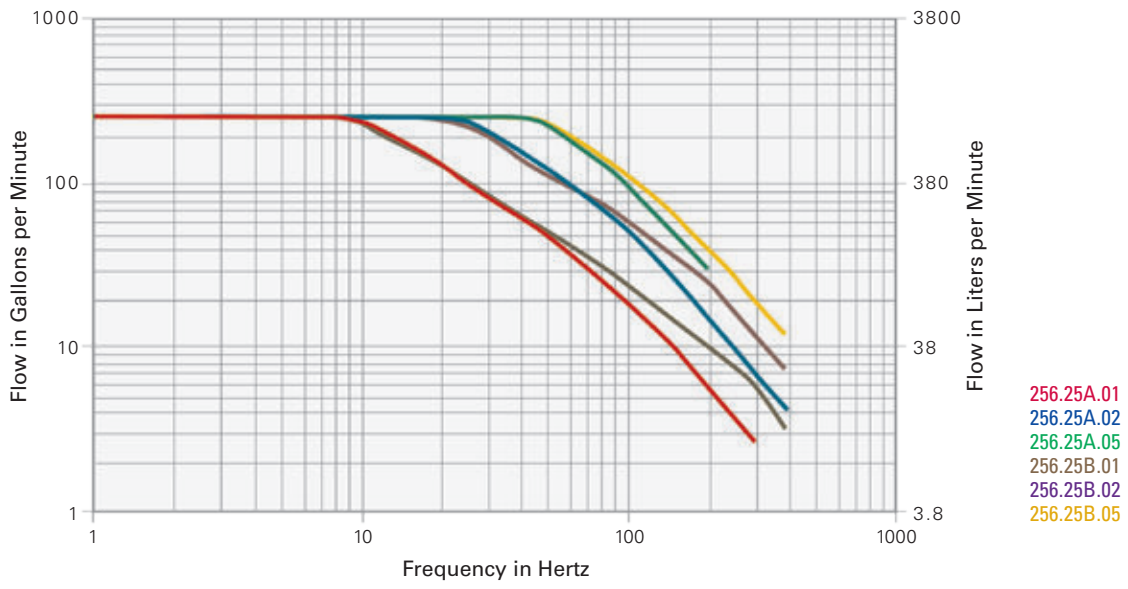

Series 257 Servovalves

MTS Series 257 Servovalves are two-stage, four-way servovalves featuring an electrodynamic pilot stage for maximum performance. These valves accommodate very high-flow closed-loop servohydraulic testing applications that require extremely high precision.

Common Applications

Series 257 Servovalves are typically used in high-frequency systems. Specifically engineered to handle very high flow rates with equally high precision, these valves tend to require a greater degree of care and attention. It is important to warm up

these valves before testing begins to avoid the risk of galling, and to check voice coil resistance every six months. Special compensation networks in the valve controller (available from MTS) help maximize dynamic performance.

- » First natural resonant frequency of 650 to 700 Hz
- » Flow ratings from 113 to 1514 lpm (30 to 400 gpm) with a 7 MPa (1000 psi) pressure drop
- » Less than 0.05% hysteresis without dither
- » Very low threshold (typically 0.02%) permits high servovalve resolution

Performance

Series 257 Servovalves consist of a high-response, voice coil-operated pilot stage (single-stage servovalve) that controls a high-flow, four-way main stage. Very stiff springs suspend the pilot, enabling a high first natural resonant frequency.

During operation, the valve controller compares the DC error to the main stage spool position indicated by the LVDT, in order to determine the magnitude and polarity of the valve command signal. This signal is sent to the power driver, which boosts it and adds damping factors to create the servovalve control signal. Then it is applied to the pilot stage voice coil to induce a magnetic field that interacts with the magnetic field of a DC-excited field coil. The difference in polarity causes the pilot spool to apply fluid to the main stage spool, which ports fluid to the actuator.

The main stage LVDT generates the servovalve feedback signal. Pilot spool movement causes the magnetic core in the linear velocity transducer to move, creating the pilot velocity feedback signal that combines with the valve command signal to allow higher inner-loop gain settings that expand system capabilities.

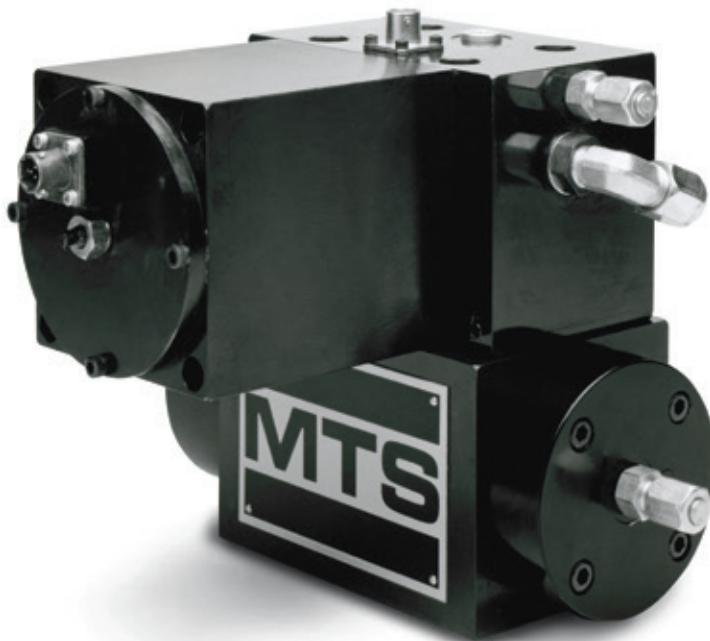
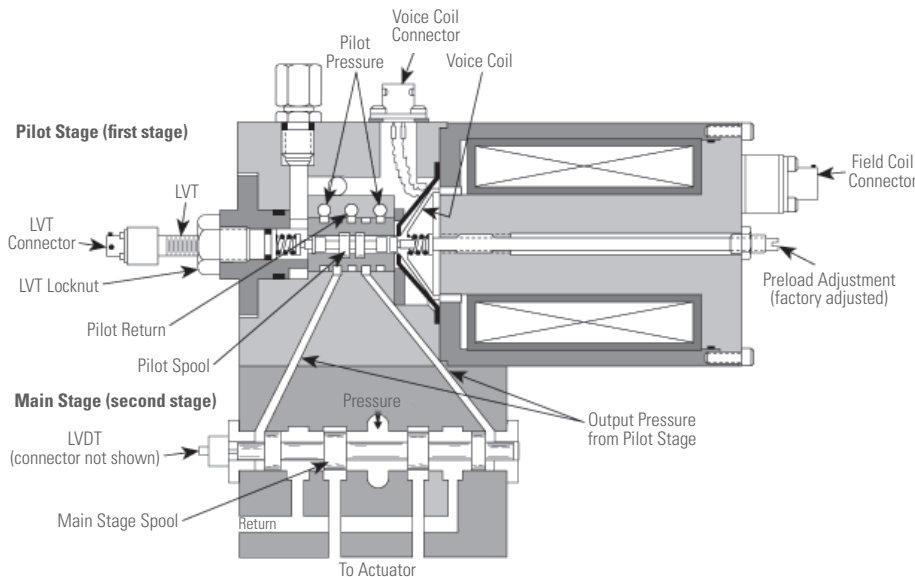

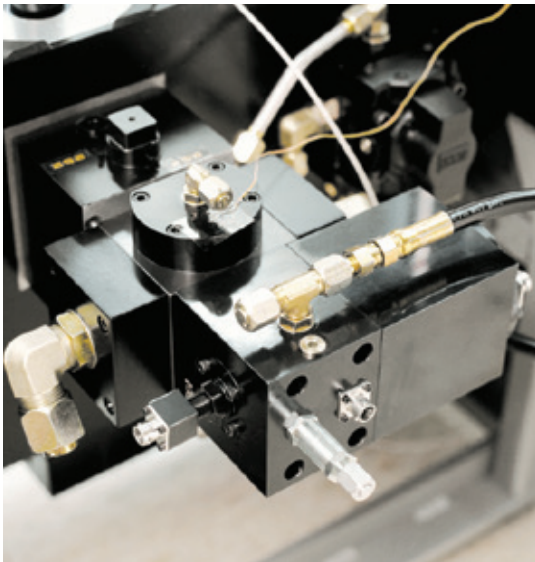

Series 257 Servovalves are engineered for high-frequency applications.

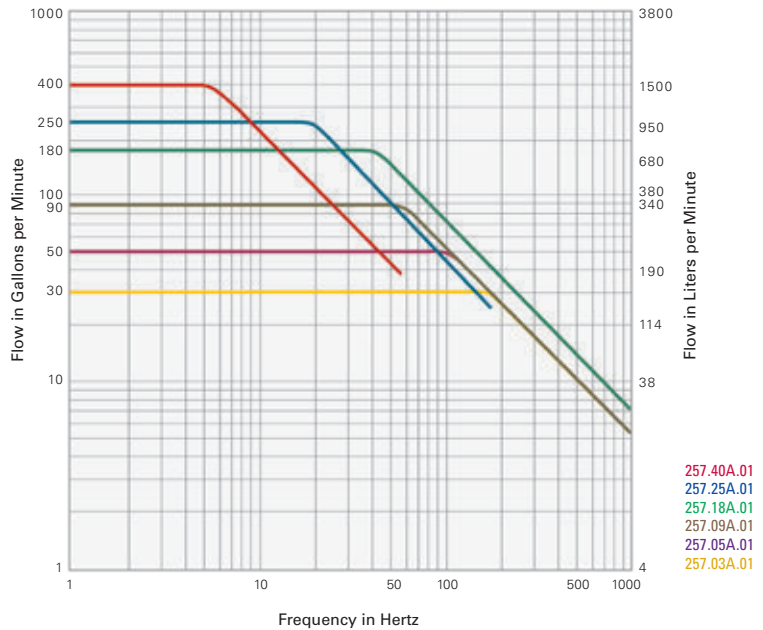

Static Servovalve Performance

Model	Parameter*											
	Rated Flow		Nominal Null Flow Gain		Null Flow		Main Stage Drain Leakage†		Null Flow-Pressure Coefficient		Main Stage Null Pressure Gain	
	L/min	gpm	L/min/% stroke	gpm/% stroke	L/min	gpm	L/min	gpm	cm ³ /kgf/sec	in. ³ /sec/psi	% supply/% stroke	
257.03A-01	113	30	1.9	0.5	7	2.0	0.083	0.022	0.33	1.4 x 10 ⁻³	80	
257.05A-01	190	50	1.9	0.5	13	3.5	0.151	0.040	0.56	2.4 x 10 ⁻³	45	
257.09A-01	340	90	6.0	1.6	13	3.5	0.151	0.040	0.56	2.4 x 10 ⁻³	150	
257.18A-01	680	180	10.6	2.8	21	5.5	0.333	0.088	0.73	3.1 x 10 ⁻³	200	
257.25A-01	950	250	16.0	4.2	23	6.0	0.340	0.090	1.38	5.9 x 10 ⁻³	160	
257.40A-01	1514	400	29.0	7.7	28	7.5	0.352	0.093	1.61	6.9 x 10 ⁻³	250	

* All values listed are typical of Series 257 Servovalves operated at the recommended hydraulic fluid filtration levels.

† Pilot stage drain leakage is 0.045 L/min (0.012 gpm).

Dynamic Servovalve Performance

Model	Parameter							
	Rated Flow*		Pilot Flow†		Full Flow Frequency (Hz)	90° Phase Signal**	Spool Stroke Rise Time	
	L/min	gpm	L/min	gpm			90% open	10% open
257.03A-01	113	30	4.73	1.25	230	250	1.7	1.5
257.05A-01	190	50	4.73	1.25	100	210	3.2	1.8
257.09A-01	340	90	4.73	1.25	60	200	4.0	2.0
257.18A-01	680	180	4.73	1.25	32	180	5.0	2.0
257.25A-01	950	250	4.73	1.25	17	130	16.1	3.0
257.40A-01	1514	400	4.73	1.25	8	100	26	4.6

* With 7 MPa (1000 psi) pressure drop across the servovalve.

† With 21 MPa (3000 psi) pressure drop across the servovalve.

** At ±10% spool stroke.

Maintenance, Care and Service

As one of the most experienced providers of servovalves, MTS can put together a configuration that meets virtually any application need. We offer a wide selection of standard products as well as more customized configurations – all of which can be carefully adapted and optimized as your application needs evolve. In addition, MTS offers a complete line of related services to ensure your servovalves deliver outstanding performance over a long life span.

Service Intervals

If hydraulic fluid is in good condition and kept clean, MTS servovalves should last a very long time without needing service. The importance of clean fluid cannot be overstated; dirty or silt-laden fluid is the major cause of servovalve problems. Typically, when valves must be serviced sooner than expected, the most likely problems are clogged filters and varnished valve spools, both of which are caused by dirty fluid. In general, fluid cleanliness should meet ISO 16/13/9 standards. The table shows recommended control limits.

Fluid Cleanliness Standards

Characteristic	Normal	Borderline	Unsatisfactory
Viscosity at 38°C (100°F) SUS	215-240	(low) 183-193 (high) 256-276	(low) <183 (high) >276
Particle count	ISO 16/13/9	ISO 17/15/11	ISO 18/16/13
Water, % by weight	<0.05	0.05 – 0.1	>0.1
Iron, ppm*	<30	30 – 50	>50
Silicon, ppm*	<15	15 – 30	>30
Copper, ppm*	<40	40 – 100	>100
TAN mg KOH/gm	<1.4	1.4 – 2.6	>2.6
Ultra Centrifugation	1 – 3	4 – 6	7 – 8
Oxidation, A/cm	<3	3 – 4	>4

Lifecycle Extension

To prevent common servovalve problems, MTS recommends maintaining fidelity through precision hydraulics management. This involves having servovalve performance tested after 7,500 hours of use (assuming fluid meets recommendations). It is also essential to monitor hard particle contaminants that lead to third-body abrasion and rapid deterioration in performance.

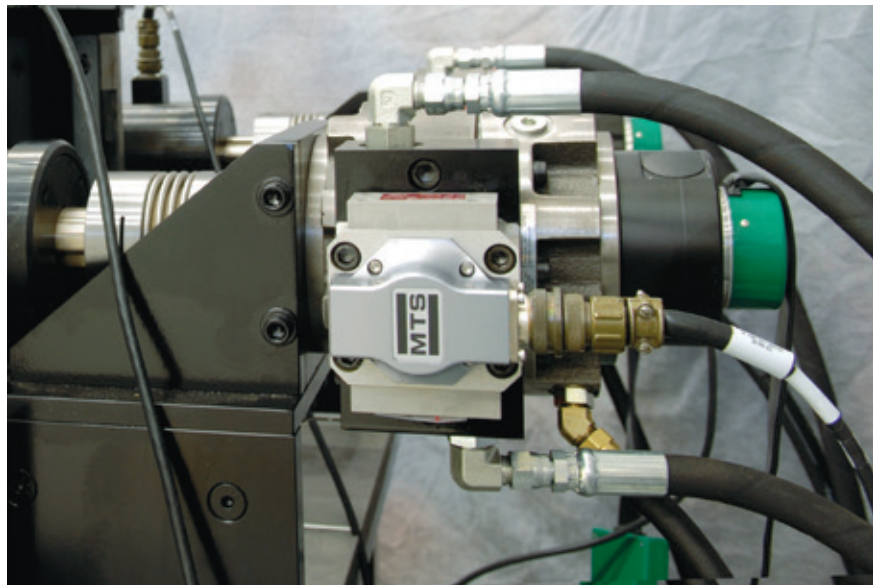

SERVOVALVE EXCHANGE

In the event of a non-functioning servovalve, the MTS servovalve exchange program gives your lab a fast, cost-effective replacement solution. Simply exchange your used servovalve for a remanufactured, tested and fully warranted product. Advantages include:

- » Good-as-new servovalve performance for less than a new replacement
- » High-quality remanufacturing performed according to stringent MTS specifications
- » 12-month warranty
- » Shipment within 24 hours (Monday through Friday)
- » Shipping carton and label for convenient return of the used servovalve core

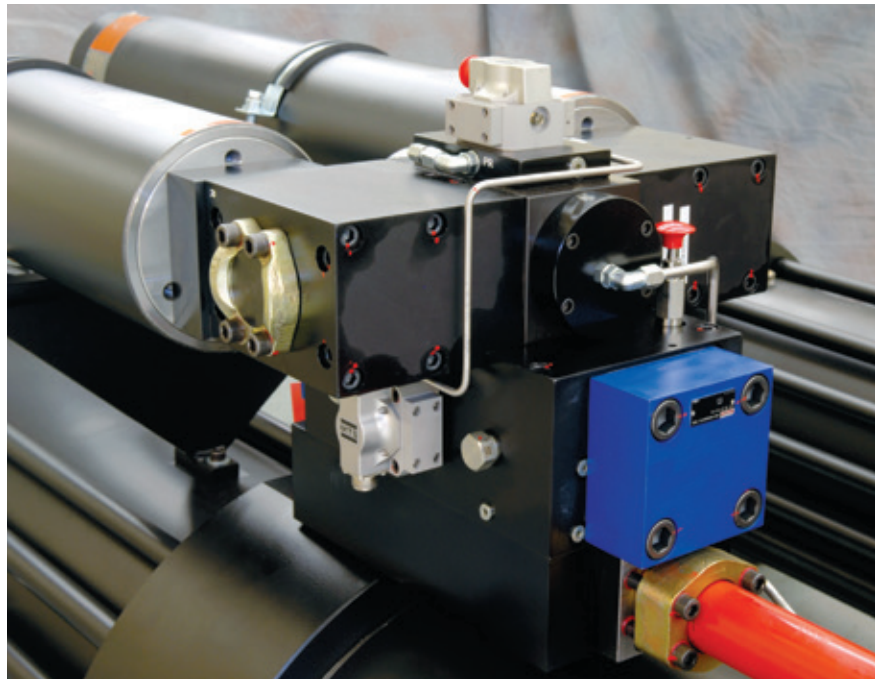

Common Problems and Solutions

- » **Whistling.** This sound may occur when system pressure is on, the actuator is not moving and the system is under control. The high-pitched noise coming from the servovalve is caused by high-speed leakage flow through metering edges, which are intentionally made to zero lap. To eliminate the noise, simply increase the return line pressure.
- » **Squeaking.** If squeaks are synchronized with actuator movement, it is likely that the spool is moving across the null position and fluid flow in the return line is unable to stop due to fluid inertia. To eliminate the noise, increase the return line pressure.
- » **Irregular movement.** Irregular actuator or servovalve movement can be caused by dirty hydraulic fluid. Contaminants temporarily clog the gap between the servovalve's flapper and nozzles, causing the servovalve and actuator to jerk. Poor system design may also be the cause. For example, hysteresis and threshold will result if a small actuator is used with a high-flow servovalve, or if the pilot stage is too big for the output stage. In general, lowering pilot supply pressure, adding a small amount of dither, and retuning the system may help improve system disturbance rejection.
- » **Squealing.** Occasionally, when a low-flow three-stage servovalve is used to control a large, long-stroke actuator, the valve will squeal when the main stage supply pressure is on; an oscilloscope shows spool oscillation, but tuning does not stop the noise. One possible source is mechanical or hydromechanical resonance. Rotating a Series 252 Servovalve 90° or 180° may cut off the mechanical feedback path. For a Series 256 Servovalve, decreasing the size of the pilot servovalve may help with squealing. Otherwise, you can eliminate squealing by adding a piece of hose to C1 or C2 port of pilot stage (-4 or -6 size, 1 to 2 feet long).

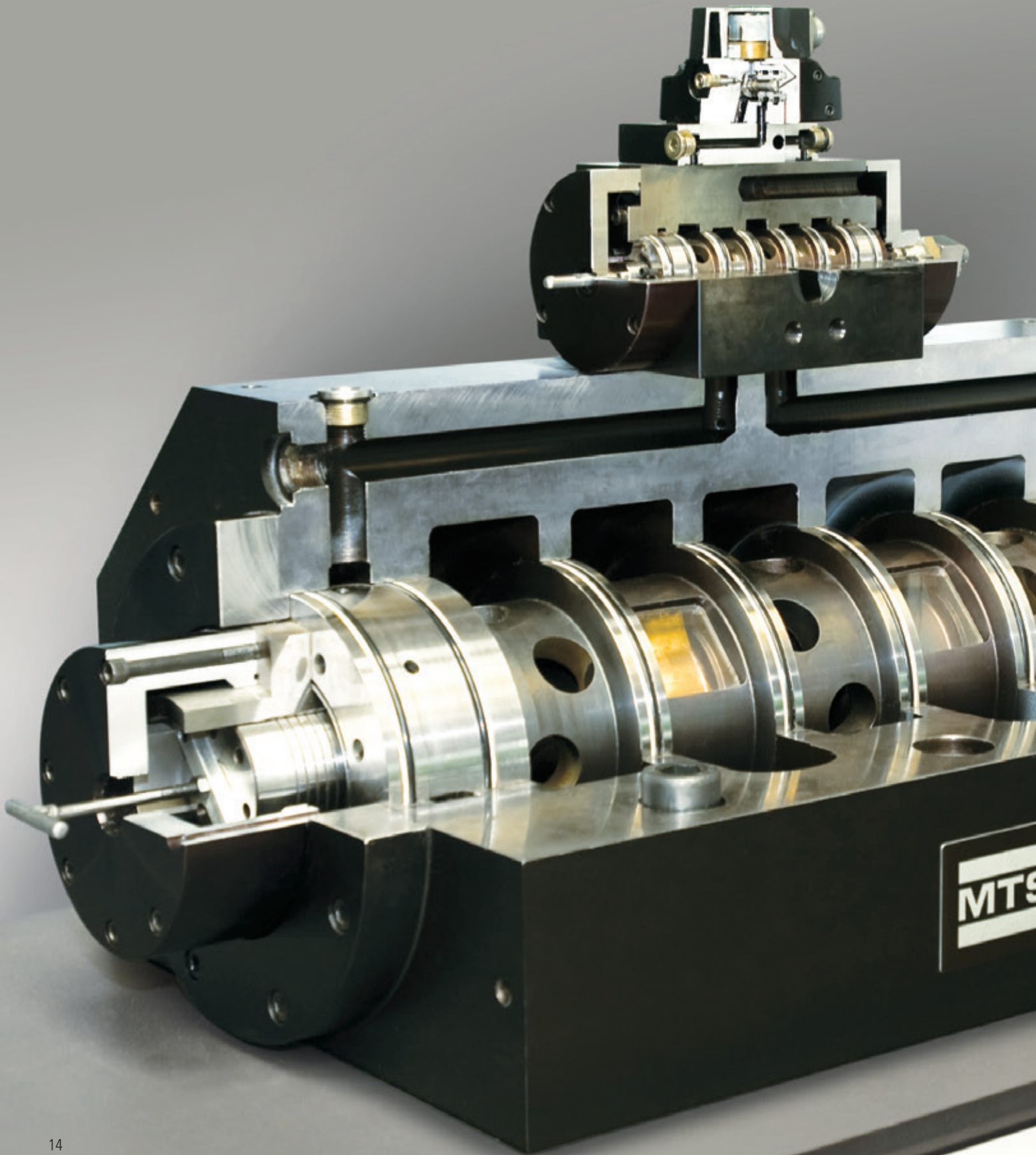

Fluid Care

Choose the MTS Fluid Care Program to protect your investment, mitigate risk of downtime, improve servovalve performance and help reduce total cost of ownership. This program combines precise fluid assessment with expert field service engineering to identify and resolve fluid contamination issues before they compromise your lab's productivity.

We work with you to design a sampling schedule that aligns with your usage and performance goals. An MTS field service engineer (FSE) then takes samples, reviews report results with you, and helps you determine if and when a maintenance intervention is required. Your FSE may also discuss results that are out of normal range, monitor trends and provide an annual summary of results, including fluid condition trend information and recommendations for future actions.

Series 252 Specifications

Maximum operating pressure	31 MPa (4500 psi)	
Minimum operating pressure	1.4 MPa (200 psi)	
Operating temperature range	-40°C to 135°C (-40°F to 275°F)	
Seals	Viton	
Rated full-flow input signal current‡	25 mA (series) 50 mA (differential) 50 mA total (parallel)	
Coil resistance	80Ω per coil	
Weight	252.2x/ 4x	1.03 kg (2.3 lb)
	252.3x	3.5 kg (7.75 lb)
Recommended hydraulic fluid	Mobil DTE 25 or Shell Tellus 46	

Series 256 Specifications

Pilot stage mating connector	MS 3106-A-14S-2S	
Pilot stage full flow current	50 mA	
Main stage mating connector	PT06 A-8-4S (SR)	
Main stage excitation	20 V p-p at 10 kHz	
Main stage impedance	200 W minimum at 10 kHz	
Main stage sensitivity	0.21 V/V per 2.54 mm (0.100 in.) stroke	
Standard operating pressure	21 MPa (3000 psi)	
Operating temperature range	-54°C to 135°C (-65°F to 275°F)	
Recommended filtration level	3-micron absolute (pilot stage) 12-micron absolute (main stage)	
Recommended hydraulic fluid	Mobil DTE 25 or Shell Tellus 46	
Seals	Buna-N	

Series 257 Specifications

Field coil connector	PT02H-8-3P	
Field coil resistance	90Ω	
Field coil working current	3.5 A	
Voice coil connector	PT02H-8-2P	
Voice coil resistance	6Ω	
Voice coil working current	3.5 A	
First natural resonant frequency	650-700 Hz	
LVT connector	PT02H-8-4P	
LVT electrical impedance	2kΩ	
LVT sensitivity	12.7 mV/cm/sec. (50 mV/in./sec.) minimum	
LVDT connector	PT02H-8-4P	
LVDT excitation	20 Vp-p at 10 kHz	
LVDT sensitivity	0.21 V/V per 2.54 mm (0.100 in.) stroke	
Standard operating pressure	21 MPa (3000 psi)	
Hydraulic fluid temperature	-40°C to 135°C (-40°F to 275°F)	
Seals	Buna-N	
Recommended filtration level	3-micron absolute (pilot stage) 10-micron absolute (main stage)	

Regional Business Centers

THE AMERICAS

MTS Systems Corporation
14000 Technology Drive
Eden Prairie, MN 55344-2290
USA
Telephone: 952-937-4000
Toll Free: 800-328-2255
E-mail: info@mts.com
Internet: www.mts.com

EUROPE

MTS Systems France
BAT EXA 16
16/18 rue Eugène Dupuis
94046 Créteil Cedex
France
Telephone: +33-(0)1-58 43 90 00
E-mail: contact.france@mts.com

MTS Systems (Germany) GmbH
Hohentwielsteig 3
14163 Berlin
Germany
Telephone: +49-(0)30 81002-0
E-mail: euroinfo@mts.com

MTS Systems S.R.L. a socio unico
Strada Pianezza 289
10151 Torino
Italy
Telephone: +39-(0)11 45175 11 sel. pass.
E-mail: mtstorino@mts.com

MTS Systems Norden AB
Datavägen 37b
SE-436 32 Askim
Sweden
Telephone: +46-(0)31-68 69 99
E-mail: norden@mts.com

MTS Systems Limited
98 Church Street,
Hunslet,
Leeds
LS102AZ
United Kingdom
Telephone: +44 (0) 113 270 8011
E-mail: mtsuksales@mts.com

ASIA/PACIFIC

MTS Japan Ltd.
Raizen Bldg. 3F 3-22-6,
Ryogoku, Sumida-ku,
Tokyo 130- 0026
Japan
Telephone: +81 3 5638 0850
E-mail: mts-j-info@mts.com

MTS Korea, Inc.
2nd F, Bundang Yemiji Building, 31,
Hwangsaoul-ro 258beon-gil,
Bundang-gu, Seongnam-si,
Gyeonggi-do, 13595
Korea
Telephone: +82-31-728-1600
E-mail: mtsk-info@mts.com

MTS Systems (China) Co., Ltd.
Floor 34, Building B,
New Caohejing International
Business Center,
No.391, Guiping Road,
Xuhui District
Shanghai 200233
P.R.China
Telephone: +021-24151000
Market: +021-24151111
Sales: +021-24151188
Service: +021-24151198
E-mail: MTSC-Info@mts.com

MTS Testing Solutions India Pvt Ltd.
No. 38, Ground Floor, Donata Radiance,
1st Cross, Tavarekere Main Road,
DRC Post, Krishna Nagar Industrial Layout,
Kormangala, Bangalore – 560 029
India
Telephone: + 91 80 46254100
Email: mts.india@mts.com



MTS Systems Corporation
14000 Technology Drive
Eden Prairie, MN 55344-2290 USA

ISO 9001 Certified QMS
<http://www.mts.com>

MTS is a registered trademark of MTS Systems Corporation in the United States. This trademark may be protected in other countries. RTM No. 211177.

©2023 MTS Systems Corporation
100-241-355b Servovalves • Printed in U.S.A. • 08/23