

IMV VIBRATION TEST SYSTEMS

m series

m

Low Acoustic Noise and Compact Range
Air Cooled Vibration Test Systems

m030/MA1-CE

IMV compact shaker (m-series) applies a permanent magnet for magnet circuit and the table diameter is 190 mm. To increase the flexibility of system extension, DC Powered cooling fan is built-in to the shaker. In normal mode, it is used for durability testing with high performance. In natural air mode (without fan), it is suitable for squeak & rattle testing. System structure is specialized for high frequency test, maximum travel of armature is almost equal to 0. Displacement of double amplitude is $10\mu\text{m}$ when excited with frequency 1kHz and acceleration 200m/s^2 . With the extension flexibility of IMV's m-series with high precision multi-point control has broaden the range of vibration test, long and large sized specimens such as exhaust pipe etc is possible as well.



1. Compact and Silent design

Silent type appropriate for abnormal noise inspection. DC powered cooling fan is built-into the shaker. Nature air cooling is also used when the cooling fan is stopped for silent operation. (with a reduction in performance.)

- Compact design
- Low noise (ideal for squeak and rattle testing)
- High precision measurement
- Low power consumption

2. m-series multi-axis system

A range of small-size systems, including 2-axis and 3-axis simultaneous systems, employing Integrated Cross Coupling Bearing Unit (ICCU) multi-axis armature / load support technology.



3. User first principle

Compatible with K2 vibration controller. Intuitive interface leads The operator with user-friendly guidance.





System Specifications (m030/MA1-CE)		
System Mode		Normal Mode
Freq. Range (Hz) *1		0 - 3000
Force	SINE (N)	300
	RANDOM (N rms)	210
	SHOCK (N)	300
Max. Acc.	No Load (m/s ²)	500
	0.5kg Load (m/s ²)	272
	1.0kg Load (m/s ²)	187
Max. Vel.	(m/s)	1.6
Max. Disp.	(mmp-p)	26

Vibration Generator (m030)	
Armature Support Method	Diaphragm spring
Armature Mass (kg)	0.6
Armature Diameter (φ mm)	114
Maximum Payload (kg)	15
Mass (kg)	22

*1) Frequency range values vary according to sensor and vibration controller.
 *2) Power supply: single-phase 100V or 200-240V, 50/60Hz. A transformer is required for other supply voltages.
 *3) Longer external cables are provided as an option.

Cooling		
Blower	Housed in vibration generator	
Power Amplifier (MA1)		
Max. Output [kVA]	1 *2	
Mass [kg]	25	
Cooling Method	Air cooling	
External cables(m)	3 *3	
Environmental Data		
Power Requirement (kVA) *2	0.4	
Input voltage supply (1 φ, V) *2	100V or 200-240V ±10% 50/60Hz	
Working Ambient Condition	Temp. (°C)	0 - 24
	Humidity (%RH)	0 - 85

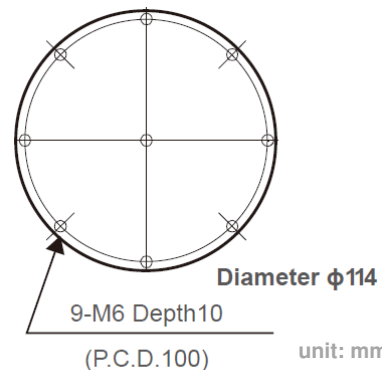

m030

Table Insert Pattern

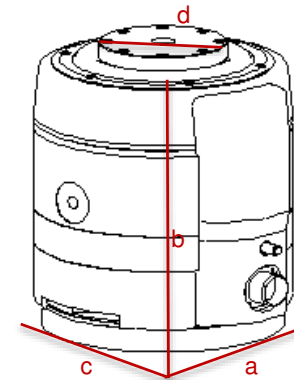

Shaker

Model: m030

- a: W190mm
- b: H 240mm
- c: D190mm
- d: 114φmm

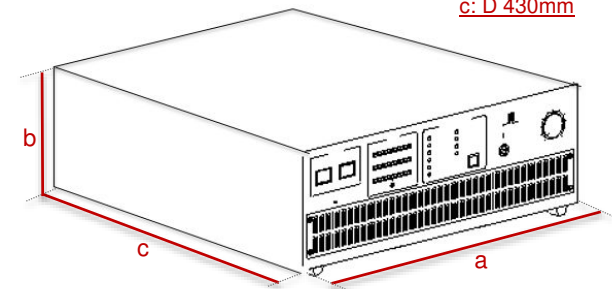

Amplifier

Model: MA1-CE

- a: W 430mm
- b: H 149mm
- c: D 430mm