

# HAWK SERIES

Rockwell | Superficial Rockwell | Brinell Hardness Testers

SEMI - **AUTOMATIC** / FULLY **AUTOMATIC**



## Front runner, with leading design features...

Protruding nose Rockwell hardness testing machines providing "inside" testing capacity with unique new features. The HAWK series can test internal diameters as small as 28mm. Inside cylinders, pipes, bores, key-nuts, U shaped parts, nuts, bolts, spacers, cardan shafts, gear box parts, any parts with difficult to reach test spots or just on flat materials as any other Rockwell hardness tester could do.

The long protruding nose allows you to reach test points as far as 165mm inside a bore or just on flat material similar to any other Rockwell hardness tester. The nose provides a throat depth of 200mm on models 250RS and 400RS-IMP. Hardness testing on any component without being hindered by a regular test head allowing an excellent overview on the workpiece.

# HAWK 250RS

The HAWK 250RS delivers the latest technology on internal Rockwell Hardness testing. A Twin Scale Rockwell machine that also provides in Brinell testing as well as the optional Vickers and Knoop impressions. Easy to use, excellent workpiece overview. The protruding nose design enables to test hardness inside objects or on external surfaces.

Unique for this system are the vertical indentation process, load cell (test force measurement) on the indenter position and the optional clamp that fixes your workpieces firmly on the test anvil. The standard version of the HAWK has a working height of 250mm and throat depth of 200mm. The I-TOUCH™ workflow controller leads you through all advanced functionality with selections to print or export data to MS Office applications or storage on a USB drive.

### ROCKWELL FORCE RANGE :

1kgf	3kgf	HAWK 250RS	150kgf	187.5kgf
------	------	------------	--------	----------

# HAWK SERIES

### HARDNESS SCALES

	<b>ROCKWELL</b>	3kgf – 150kgf
	<b>BRINELL</b>	1kgf - 187.5kgf
		Vickers & Knoop scales optional



### HIGHLIGHTS

- 1 150mm protruding nose, 200mm throat depth
- 2 Load Cell, Closed loop, force feedback system
- 3 Force (load) measurement at the indenter position
- 4 Absolute linear applied test force, no lever construction
- 5 Hysteresis free mechanical system
- 6 250mm workpiece height
- 7 Power LED light near indenter for bright sample illumination
- 8 Removable workpiece clamp, with interchangeable inserts, clamps/holds sample firmly in position (Optional)
- 9 I-TOUCH™, software system, advanced tester control
- 10 Industrial 6.5" industrial touchscreen
- 11 USB connectivity
- 12 ABS covers included, protecting machine base against falling objects
- 13 Optional Brinell microscope package, for Brinell measurements

# HAWK 400RS

The HAWK 400RS is a taller version of the 250RS. Similar to the 250RS it provides a vertical indentation process, load cell (test force measurement) on indenter position and the optional clamp that fixes your workpieces firmly on the test anvil or table.

This taller version of the HAWK increases the sample height to 400 mm while maintaining the 200 mm throat depth. When selecting the option of the automatic spindle, the full process of lifting, clamping, test procedure on your sample will be performed by only 1 touch of the "Start" icon on the touchscreen. The I-TOUCH™ workflow controller effortlessly leads you through all advanced functionality including options to print or export data to MS Office applications or to store files on a regular USB drive.

## ROCKWELL FORCE RANGE :

1kgf	3kgf	HAWK 400RS	150kgf	187.5kgf
------	------	------------	--------	----------

# HAWK 400RS-IMP

The HAWK 400RS-IMP shares all functionality available on the 400RS such as working height of 400mm and throat depth of 200mm and can be optionally equipped with an automatic spindle. Simply push "START" and the full process of lifting, clamping and testing takes place without operator interference.

Moreover, the 400RS-IMP has an integrated Industrial PC, running Windows 10 and the INNOVATEST IMPRESSIONS™ MT workflow tester control software and a larger touchscreen with even more functionality. The system has all nowadays available connectivity such as LAN, WLAN, USB. Advanced tester operation and on screen guidance as well as remote service capabilities via INNOVATEST Team Viewer.



## ROCKWELL FORCE RANGE :

1kgf	3kgf	HAWK 400RS-IMP	150kgf	187.5kgf
------	------	----------------	--------	----------

## HARDNESS SCALES

-  **ROCKWELL** 3kgf – 150kgf
  -  **BRINELL** 1kgf - 187.5kgf
- Vickers & Knoop scales optional

## HARDNESS SCALES

-  **ROCKWELL** 3kgf – 150kgf
  -  **BRINELL** 1kgf - 187.5kgf
- Vickers & Knoop scales optional

Smallest bore  
28 mm

Clamp installed

## HIGHLIGHTS

- 1 150mm protruding nose, 200mm throat depth
- 2 Load Cell, Closed loop, force feedback system
- 3 Force (load) measurement at the indenter position
- 4 Absolute linear applied test force, no lever construction
- 5 Hysteresis free mechanical system
- 6 400mm workpiece height
- 7 Power LED light in nose for bright sample illumination
- 8 Removable workpiece clamp, with interchangeable inserts, clamps/holds sample firmly in position (Optional)
- 9 I-TOUCH™, software system, advanced tester control
- 10 Industrial 6.5" industrial touchscreen
- 11 USB connectivity
- 12 ABS covers included, protecting machine base against falling objects
- 13 Optional Brinell microscope package, for Brinell measurement

## HIGHLIGHTS

- 1 150mm protruding nose, 200mm throat depth
- 2 Load Cell, Closed loop, force feedback system
- 3 Force (load) measurement at the indenter position
- 4 Absolute linear applied test force, no lever construction
- 5 Hysteresis free mechanical system
- 6 400mm workpiece height
- 7 Motorized spindle for fully automatic clamping & testing (optional)
- 8 Power LED light in nose for bright sample illumination
- 9 Removable workpiece clamp, with interchangeable inserts, clamps/holds sample firmly in position (Optional)
- 10 Integrated high performance system controller, mSSD hard drive storage
- 11 MS Windows 10 licensed, IMPRESSIONS™ MT tester control software
- 12 Industrial 8.5" touchscreen
- 13 Lan, W-LAN, USB connectivity, remote support software pre-installed
- 14 Wireless keyboard & mouse
- 15 ABS covers included, protecting machine base against falling objects
- 16 Optional BIOS Brinell Indent Optical Scanner for automatic Brinell measurements

# HAWK 651RS

Testing larger, irregular shaped or long work pieces is a challenge on spindle machines. The product first needs to fit on the test anvil and then has to be lifted to the correct position for testing. In particular for nose type hardness testing, it gets difficult if you need to test the inside hardness of a large diameter sample. The 651RS addresses these concerns by being supplied with a large 425x370mm testing table with a hardened test area inlay that also gives space to the mounting of all kind of anvils for particular purpose, such as flat, v-shaped or spot anvils.

No need to fear falling objects or parts as such parts now don't need to be lifted in position anymore. The linear slide that contains the protruding nose of 175mm long can be rapidly moved in to position by a precision ball bearing spindle. On the full working height of the machine a high precision measuring system determines the actual position of the nose during movement and while testing.

## ROCKWELL FORCE RANGE :

1kgf	3kgf	HAWK 651RS	150kgf	187.5kgf
------	------	------------	--------	----------

# HAWK 652RS-IMP

The 652RS-IMP is the most technically advanced model in the group of HAWK testers. Not only has this model been equipped with an integrated fanless Industrial PC, running Windows 10 and the Innovatest full version of IMPRESSIONS™ workflow, tester control software. Advanced tester operation at your fingertips.

Unique and alone in the world is the advance technology of a double Z axis system providing 650mm working height, but also different test positions for your special shaped samples. The second adjustable position can support a wide range of different and specialized anvils or tables to support your test piece from the inside, outside, top or the bottom. No more time consuming of cutting, grinding and polishing of your samples for a couple of hardness tests.

## ROCKWELL FORCE RANGE :

1kgf	3kgf	HAWK 652RS-IMP	150kgf	187.5kgf
------	------	----------------	--------	----------

## HARDNESS SCALES



**ROCKWELL** 3kgf – 150kgf

## HARDNESS SCALES



**ROCKWELL** 3kgf – 150kgf



**BRINELL** 1kgf - 187.5kgf

Vickers & Knoop scales optional

## HIGHLIGHTS

- 1 175mm protruding nose, 175mm throat depth
- 2 Load Cell, Closed loop, force feedback system
- 3 Force (load) measurement at the indenter position
- 4 Full height linear slide, hysteresis free mechanical system
- 5 650mm workpiece height
- 6 Large worktable 425mm x 370mm + T-slots and hardened anvil 200mm
- 7 Removable anvil plate allows inserting special anvils
- 8 Power LED light in nose for bright sample illumination
- 9 I-TOUCH™, software system, advanced tester control
- 10 Industrial 6.5" industrial touchscreen
- 11 USB connectivity
- 12 ABS covers included, protecting machine base against falling objects

## HIGHLIGHTS

- 1 175mm protruding nose, 175mm throat depth
- 2 **Second Z-axis anvil & stage holder, motorized ball bearing travel**
- 3 Load Cell, Closed loop, force feedback system
- 4 Force (load) measurement at the indenter position
- 5 Full height linear slide, hysteresis free mechanical system
- 6 650mm workpiece height
- 7 Large worktable 425mm x 370mm + T-slots and hardened anvil 200mm
- 8 Removable anvil plate allows inserting special anvils
- 9 Power LED light in nose for bright sample illumination
- 10 **Integrated high performance system controller, mSSD hard drive storage**
- 11 **MS Windows 10 licensed, IMPRESSIONS™ tester control software**
- 12 **Industrial 15" touchscreen**
- 13 LAN, W-LAN, USB connectivity, remote support software pre-installed
- 14 ABS covers included, protecting machine base against falling objects
- 15 Optional BIOS Brinell Indent Optical Scanner for automatic Brinell measurements

## 4 UNIQUE FEATURES OF THE HAWK 250-400

### 1 PERFECT VERTICAL INDENTATION

Similar type of machines on the market use a lever arm that has a significant disadvantage on accuracy as the indenter makes a circle movement ( see additional info sheet) and either pushes or pulls the workpiece over the anvil. The indenter has a tendency to “dig” a hole in the workpiece and as such creates imperfect non-linear measurements that require either mechanical, electronic/ software compensation.

The protruding nose of the HAWK Series is fixed to a perfect linear moving mechanism driven by a high precision ball bearing spindle eliminating all possible indenter movement in any other horizontal direction while while being free from any hysteresis.

### 2 LOAD CELL (FORCE SENSOR) POSITION

In most Load Cell, Closed loop hardness testers the load cell is part of the force application system inside the machine. Such load cell position is being influenced by mechanical imperfections subject to wear and tear of the mechanism.

For the HAWK series, like in most INNOVATEST machines, we have designed a load cell that is positioned directly above the indenter in the ultimate front part of the nose. In this way, over many years of use any potential wear and tear inside the hardness tester will have no affect on the accuracy of the force measurement.

### 3 WORKPIECE CLAMP

HAWK models 250 and 400 have a cutting edge technology workpiece clamp that is unmatched in performance even from other similar type of machines. The clamp can simply be installed above the protruding nose and workpieces can be firmly clamped on anvils and test tables eliminating unwanted hysteresis or movement during the test. The clamp has interchangeable contact points for flat, convex, or concave shaped parts. For parts where space matters, the clamp can be removed in just seconds.

### 4 INTEGRATED SYSTEM CONTROLLER, WINDOWS 10

The HAWK 400RS-IMP is equipped with an Industrial “fanless” heavy duty PC system running Windows 10 and IMPRESSIONS™ MT workflow software system\*. HAWK 400RS-IMP can easily connect via USB, LAN, WLAN and Bluetooth with any network.



HAWK 250RS

HAWK 400RS-IMP\*

It is more the need than the want that drives technical innovation...

## 5 UNIQUE FEATURES OF THE HAWK 651-652

### 1 PERFECT VERTICAL INDENTATION

Most similar type of machines on the market use a lever arm that has significant disadvantage on accuracy as the indenter makes a circle movement ( see additional info sheet) and either pushes or pulls the workpiece over the anvil. The indenter has a tendency to “dig” a hole in the workpiece and as such creates imperfect non-linear measurements that require either mechanical, electronic/ software compensation.

The protruding nose of the HAWK Series is fixed to a perfect linear moving mechanism driven by a high precision ball bearing spindle eliminating all possible indenter movement in any other horizontal direction while being free from any hysteresis.

### 2 LOAD CELL (FORCE SENSOR) POSITION

In most Load Cell, Closed loop hardness testers the load cell is part of the force application system inside the machine. Such load cell position is being influenced by mechanical imperfections subject to wear and tear of the mechanism.

For the HAWK series, like in most INNOVATEST machines, we have designed a load cell that is positioned directly above the indenter in the ultimate front part of the nose. In this way, over many years of use any potential wear and tear inside the hardness tester will have no affect on the accuracy of the force measurement.

### 3 DUAL Z-AXIS WORK PIECE SUPPORT

Never seen before in the hardness testing world is the new HAWK 652RS-IMP. Eyebrow raising unique feature of both a fixed large testing table, or a double Z-axis on demand.

The bottom jaw is driven by a second ball bearing spindle, raises out of the base of the tester and can hold any anvil for any kind of testing requirements. Testing steel flanges, pipes, inside and outside while hanging them on the bottom jaw for excellent support has now been made possible on this unique in the field machine. No more need for time consuming sample cutting.

### 4 UP TO 650MM WORKING HEIGHT

The HAWK 651 and 652 models with fixed work table can handle really large and heavy workpieces. On these models, the vertical capacity can raise up to 650mm while the table can carry up to a 1000kgs load.



HAWK 651RS

HAWK 652RS-IMP

### 5 INTEGRATED SYSTEM CONTROLLER, WINDOWS 10

The HAWK 652RS-IMP is equipped with an Industrial “fan-less” heavy duty PC system running Windows 10 and a full version of the IMPRESSIONS™ workflow software system. Handle any challenging requirement. HAWK 400RS-IMP and 652RS-IMP can easily connect via USB, LAN, WLAN and Bluetooth with any network or quality assurance software like, but not limited to Q-Das.

# HAWK RANGE

Excellent quality, best in class sensor technology and measuring devices such as force sensors placed on the only right position, straight above or connected to the indenter.

By design the depth measuring sensor is directly connected to the front of the load mechanism on the nose itself.

The 250 and 400 series are equipped with a unique load mechanism that has no moving pivot points and is 100% free of hysteresis. The 651RS and 652RS-IMP have a linear Z-axis able to provide up to 150kgf on 650mm height without any loss of measuring accuracy. Therefore all HAWK models come as a standard with a 2 year warranty on the machine structure and on other parts.



HAWK 250RS



HAWK 400RS



HAWK 400RS-IMP



HAWK 651RS



HAWK 652RS-IMP

## Above the current...

The backbone of our process for new product innovation is the marriage of combining market experiences, real life experiences, needs and improved technical solutions. Designing & implementing a new product range starts with an absolute free mind, providing limitless creation freedom. The HAWK series are an excellent example of creation freedom, making a new ground breaking product available that stands far above the current.

# HAWK RANGE

Technology that sets the standard...

## LINEAR TECHNOLOGY

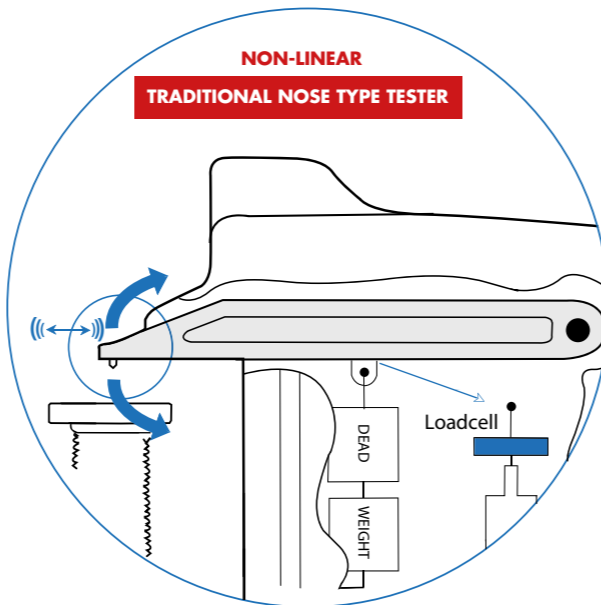
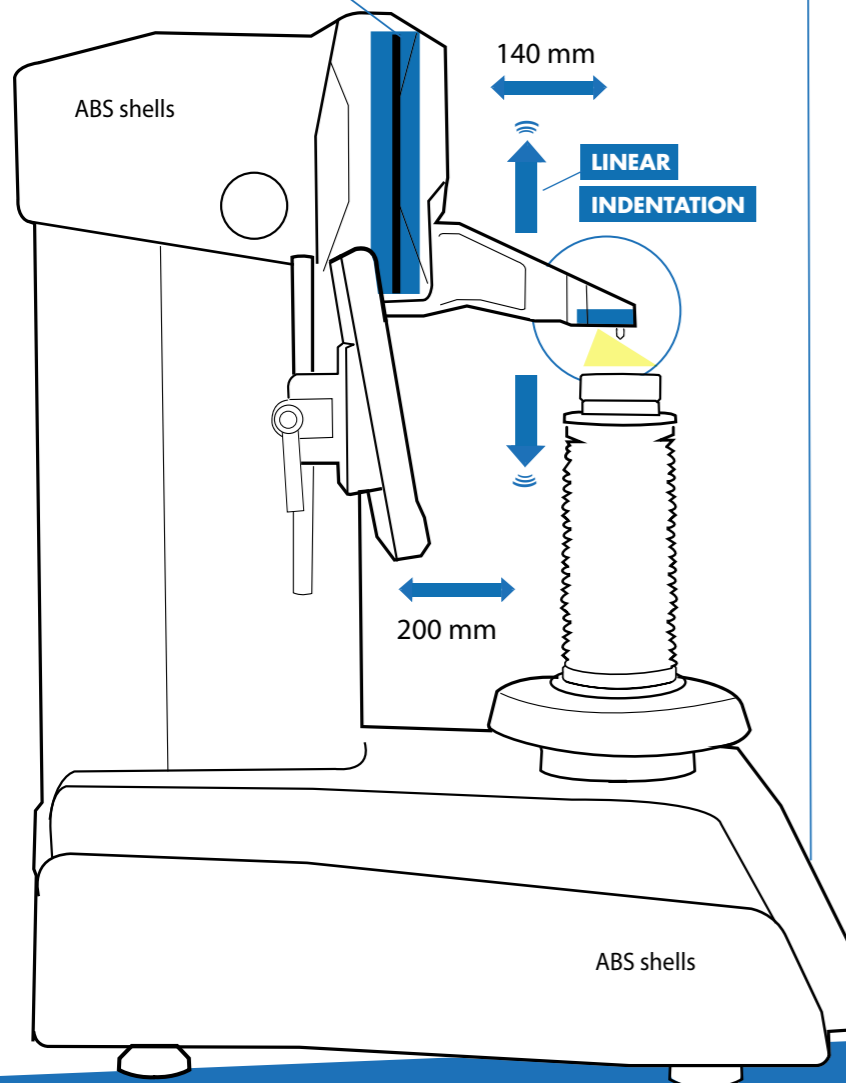

Traditional nose type hardness testers have the disadvantage that the indenter is fixed to a long load application arm that makes a circular movement. Due to this construction, the indenter is not only pushed but also dragged through the material with horizontal displacement.

The result can be best compared with digging into the material. It requires software and hardware compensation to minimize the "error" it creates in hardness values.

The HAWK series have a hysteresis free vertical slide resulting in Rockwell and Brinell indents of perfect shape without the need of correcting algorithms in the final hardness calculation.

### MOTORIZED AUTOMATIC SPINDLE Z-AXIS

Fully automatic motorized spindle, upload, pre-load, test, unload, recovery and park, where the clamp either releases or holds the sample after testing.

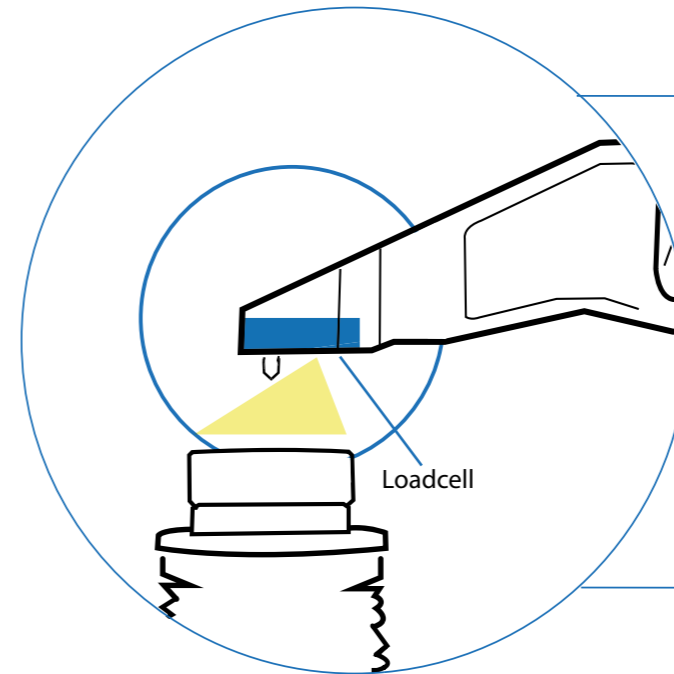

### FORCE MEASUREMENT AT INDENTER POSITION

Closed loop system (no dead weights) with world's most comprehensive force measurement system ever seen on this type of hardness testing machine. Precision engineering and top-class manufacturing to assure that the test force is being measured on the only right location, the seating of the indenter. This unique system eliminates any and all irregularities in the testers force application system.

### WORKPIECE CLAMP AND PERFECT SHAPED INSERTS

Another real novelty on the HAWK series is the workpiece clamp that holds workpieces firmly in position while performing a test.

A set of 7 differently shaped (convex, concave, V-grooved or flat) clamp inserts allow to assure perfect grip on the sample.

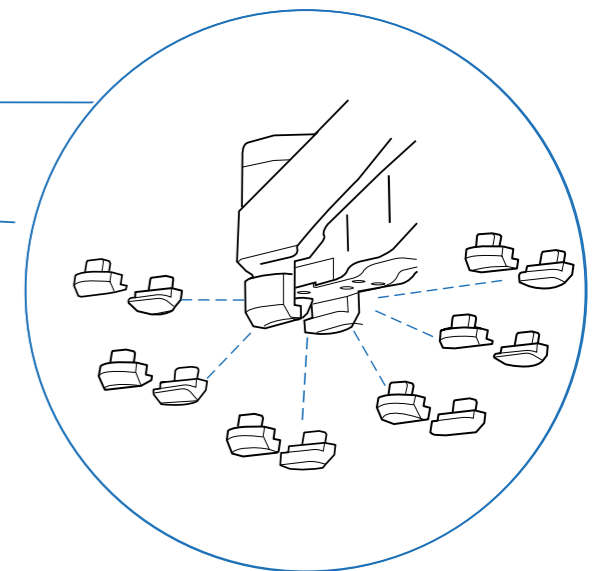

HAWK 250/400



# EXCEPTIONAL FEATURES

Reach, what could not be reached, nearly unlimited testing options with a stunning accuracy performance.



# EXCITING ABILITIES

A unique product for nearly endless applications...

An unlimited choice of anvils that can be placed in either the table base or the secondary Z-axis. Avoid time consuming and expensive sample cutting and sample preparation, test, what could not be tested before.

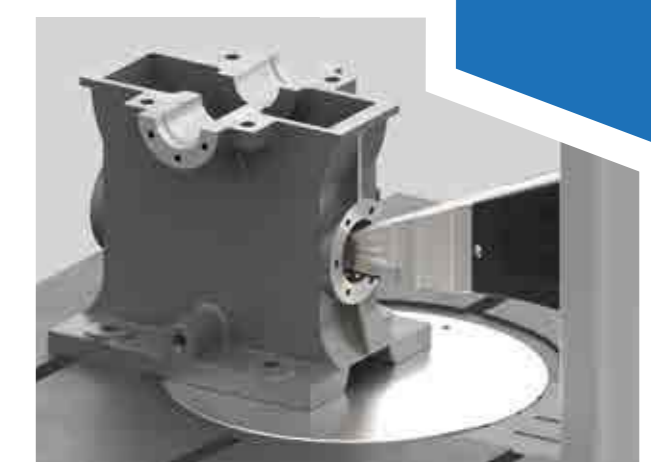

HAWK 651RS

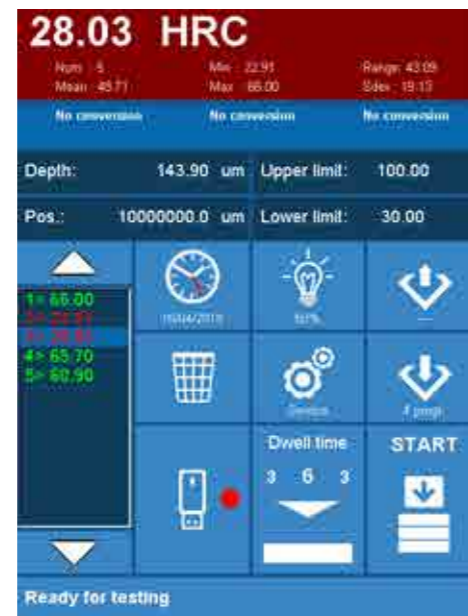

## I-TOUCH™

I-TOUCH™ sensibility and simplicity

I-TOUCH™, a combination of an industrial touchscreen and smart software features. The full Color GUI is operated with your fingertips and provides ultimate user comfort. Setting up the tester for a particular scale or job has never been more easy. No real operator skills are required as you easily find your way throughout the functions of this system.

Single readings, multiple readings, add, delete or edit measurements, store or export the test results as single readings or batches, connect to a USB drive for unlimited memory or just to download the data on the USB drive to further process it at regular PC.

# INNOVATIVE SOFTWARE

## IMPRESSIONS™

### Advanced workflow control...

IMPRESSIONS™ hardness tester workflow and control software is the heart of the 400RS-IMP or the 652RS-IMP. The system runs on a powerful integrated industrial PC driven by MS Windows. Either a 8.5" (400RS-IMP) or 15" (652RS-IMP) portrait positioned industrial touchscreens give access to a treasure of functionality.

Single measurements, batch measurements statistics, conversions and other data obtained from the test procedure can be stored on the internal hard drives or shared via LAN or WLAN connectivity. IMPRESSIONS™ works via LAN protocol with robots or other factory automation or quality control systems like Q-Das. It also supports motorized CNC X-Y stages or jominy test set up.



Combine Brinell IMPRESSIONS™ optical scanner or analogue Brinell pack with the HAWK series

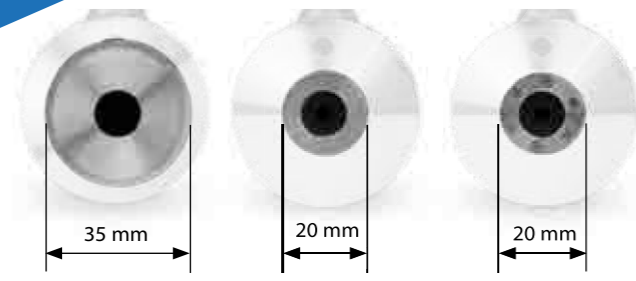

NON-MAGNETIC XL    NON-MAGNETIC    MAGNETIC

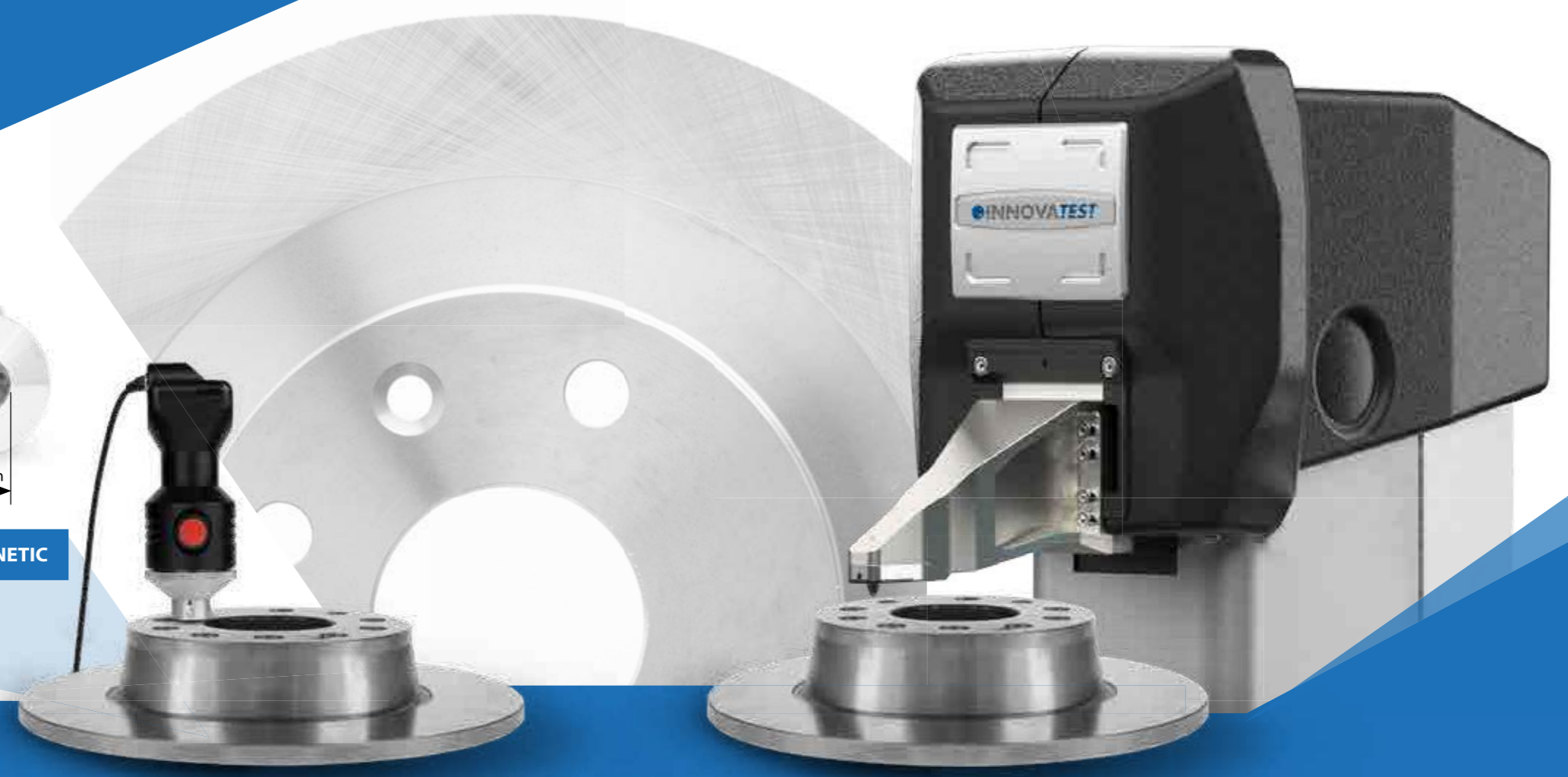

# BRINELL

## MEASUREMENT SYSTEM

Experience the advantage of intuitive operation...

Either the BIOS (Brinell Indent Optical Scanner) or a simple handheld microscope can be combined with the software of the Hawk 250, 400 and 652 models.

The BIOS is supplied as a package including Brinell measurement software integrated in the IMPRESSIONS™ software of the HAWK series. With a simple click on the measure button integrated on the camera or just the measure button on the display, the BIOS scans the sample surface for Brinell indents, measures & determines the Brinell hardness value automatically

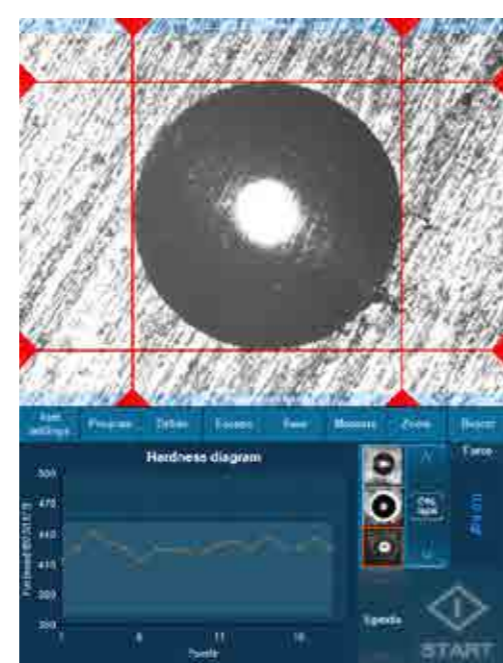
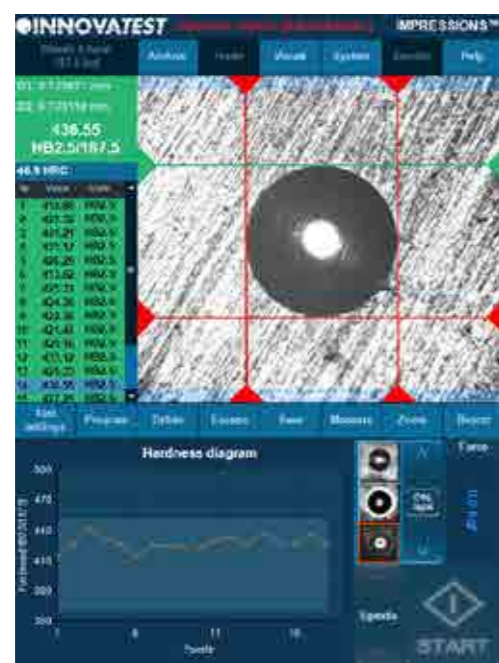

# ACCESSORIES

## HAWK 250-400

Schematic overview of the configuration options, standard and optional accessories

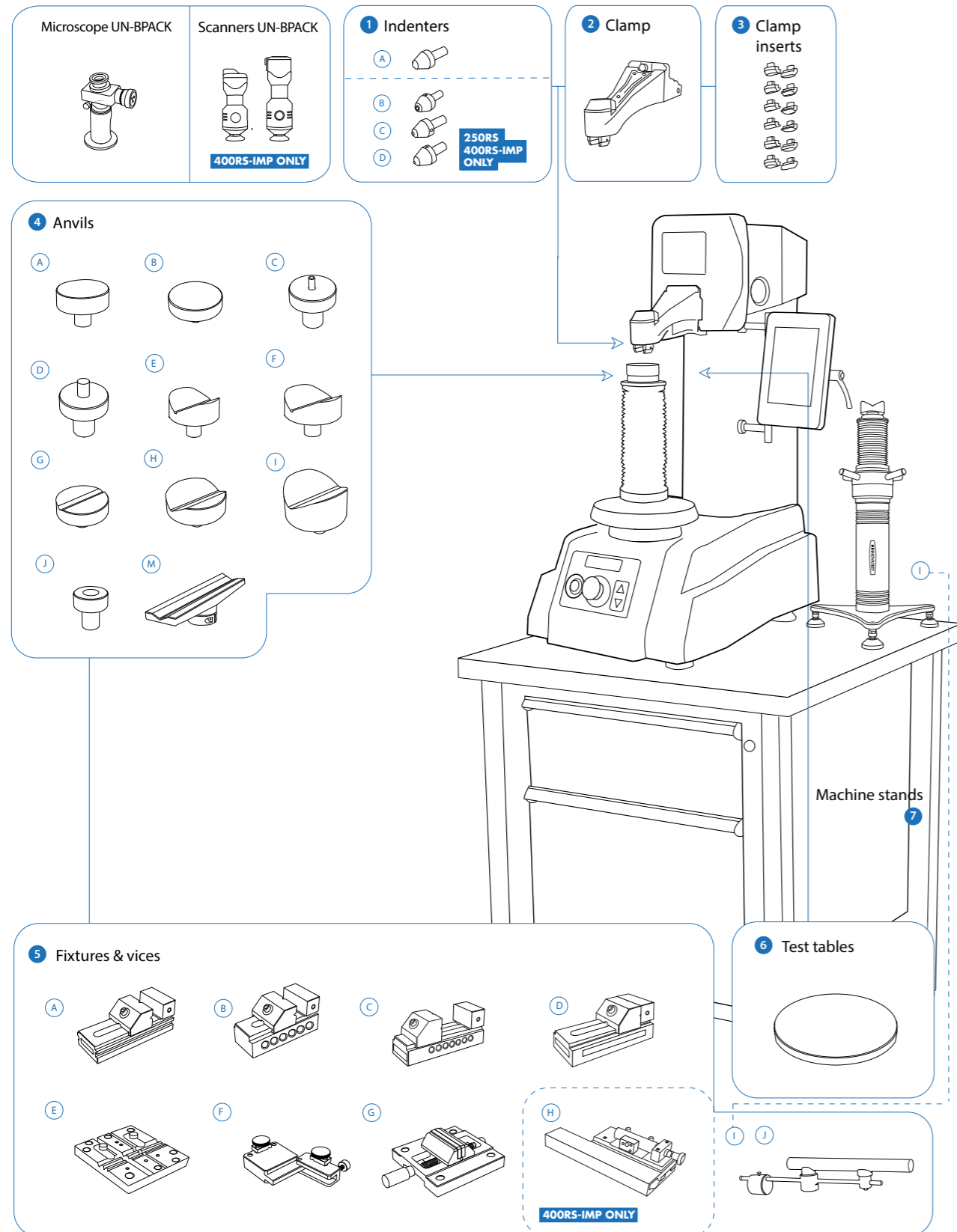

Not all accessories are displayed on this page. Full details can be found on the Order details page.

# ACCESSORIES

## HAWK 651-652

Schematic overview of the configuration options, standard and optional accessories

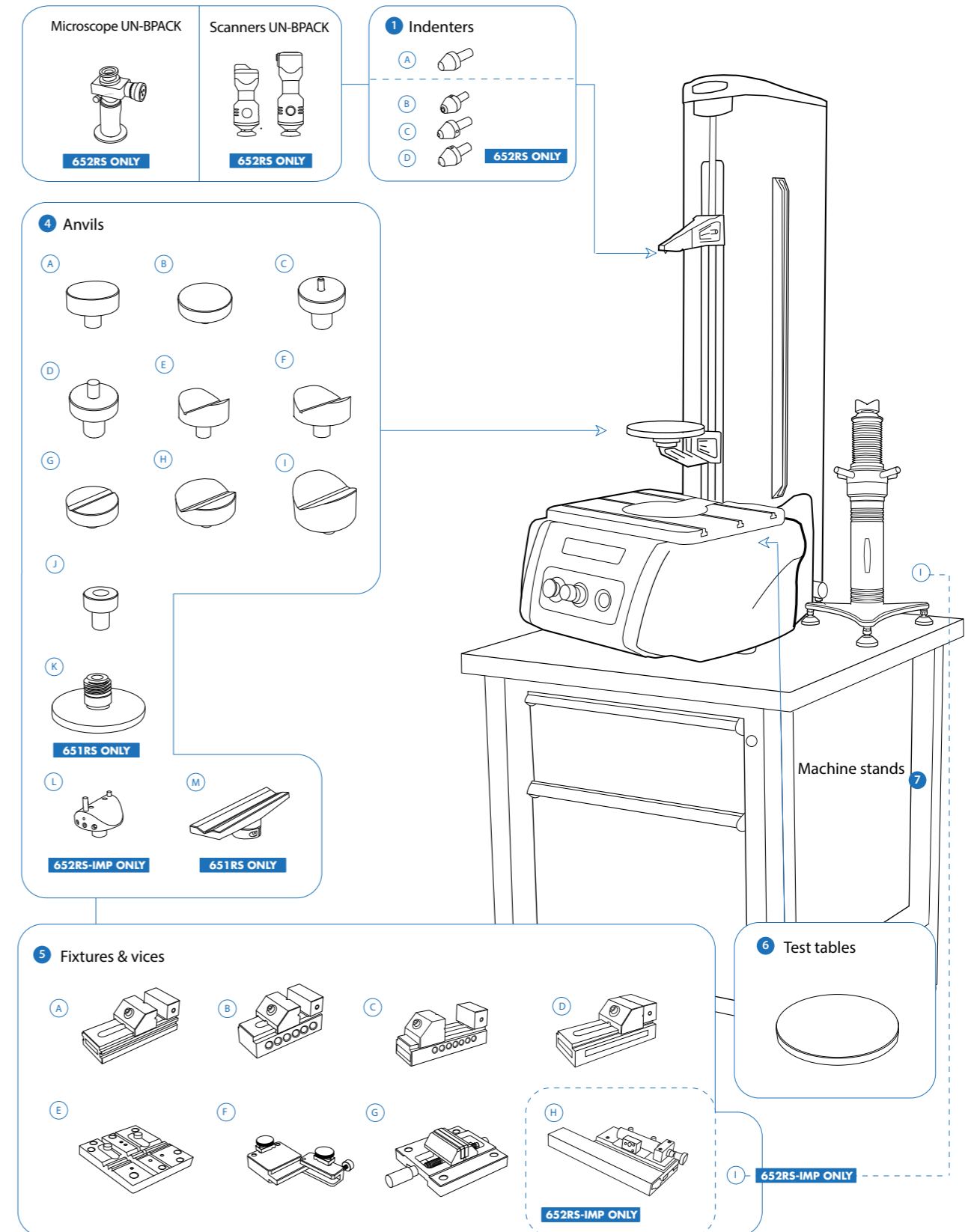

Not all accessories are displayed on this page. Full details can be found on the Order details page.

# ORDER DETAILS

## HAWK SERIES



Fully automatic, load cell, closed loop, Rockwell hardness tester 1kgf - 187.5kgf	HAWK 250RS	
Fully automatic, load cell, closed loop, Rockwell hardness tester 1kgf - 187.5kgf	HAWK 400RS	
Fully automatic, load cell, closed loop, Rockwell hardness tester 1kgf - 187.5kgf	HAWK 400RS-IMP	
Fully automatic, load cell, closed loop, Rockwell hardness tester 3kgf - 150kgf	HAWK 651RS	
Fully automatic, load cell, closed loop, Rockwell hardness tester 1kgf - 187.5kgf	HAWK 652RS-IMP	
Plug & Play prepared, calibration, sea & airworthy packing in "non coniferous wood" material (for 250RS, 400RS & 400RS-IMP)	P&PSEAPACK210	
Plug & Play prepared, calibration, sea & airworthy packing in "non coniferous wood" material (for 651RS & 652RS-IMP)	P&PSEAPACK220	

## ACCESSORIES

	Spindle	Auto spindle (for 400RS & 400RS-IMP)	SA-03-0034		
1	Indenters	A	Rockwell C Diamond Indenter. Ø3mm. ISO & ASTM certified (for all models)	IN/6003	
			Rockwell diamond indenter Ø3mm, ISO & ASTM certified L=12mm	IN/6004	
			Rockwell Ball Indenter 1/16". Includes 1 carbide ball. Ø3mm. ISO & ASTM certified (for all models)	IN/7503	
			Rockwell Ball Indenter 1/8". Includes 1 carbide ball. Ø3mm. ISO & ASTM certified (for all models)	IN/7603	
			Rockwell Ball Indenter 1/4". Includes 1 carbide ball. Ø3mm. ISO & ASTM certified (for all models)	IN/7703	
			Rockwell Ball Indenter 1/2". Includes 1 carbide ball. Ø3mm. ISO & ASTM certified (for all models)	IN/7808	
			B	Brinell Indenter 1mm. Includes 1 carbide ball. Ø3mm. ISO & ASTM certified (for 250RS, 400RS, 400RS-IMP & 652RS-IMP)	IN/7001
			Brinell Indenter 2.5mm. Includes 1 carbide ball. Ø3mm. ISO & ASTM certified (for 250RS, 400RS, 400RS-IMP & 652RS-IMP)	IN/7006	
			Brinell Indenter 5mm. Includes 1 carbide ball. Ø3mm. ISO & ASTM certified (for 250RS, 400RS, 400RS-IMP & 652RS-IMP)	IN/7011	
			C	(Micro Vickers Indenter Ø3mm, ISO & ASTM certified (for 250RS, 400RS, 400RS-IMP & 652RS-IMP)	IN/8105
D	Micro Knoop Indenter Ø3mm, ISO & ASTM certified (for 250RS, 400RS, 400RS-IMP & 652RS-IMP)	IN/8205			
2	Clamp	Clamping nose (for 250RS, 400RS & 400RS-IMP) with a set of 2 flat pieces (CM-02-0304) + electronics	SA-02-0110		
3	Clamp inserts	Clamp nose piece -flat (set of 2) standard included for SA-02-0110	CM-02-0304		
		Clamp nose piece -V-25-38 (purchase per two required)	CM-02-0313		
		Clamp nose piece -V-38-70 (purchase per two required)	CM-02-0311		
		Clamp nose piece -V-70-150 (purchase per two required)	CM-02-0315		
		Clamp nose piece -concave-R-30 (purchase per two required)	CM-02-0314		
		Clamp nose piece -convex-R-30 (purchase per two required)	CM-02-0312		

4	Anvils	A	Flat anvil 60mm	AS3000-19-04		
		B	Flat anvil 80mm	UN-TESTTABLE/002		
		C	Spot anvil 5mm	UN-ANVIL/010		
		D	Spot anvil 10mm	UN-ANVIL/011		
		E	V-anvil ø40mm 6-60mm	UN-ANVIL/005		
		F	V-anvil ø63mm 10-100mm	UN-ANVIL/006		
		G	V-Anvil ø80mm 3.3-20mm	UN-ANVIL/040		
		H	V-Anvil ø80mm 12-80mm	UN-ANVIL/045		
		I	V-Anvil ø80mm 20-140mm	UN-ANVIL/050		
		J	Anvil for round specimen dia. 6-25,4mm	UN-ANVIL/200		
			Test table 100x100mm, V groove 20mm wide, 10mm deep	UN-TESTTABLE/040		
		K	Stage anvil adapter (for 651RS)	SA-08-0006		
		L	Ring support anvil kit (for 652RS-IMP)	SA-08-0007		
		M	Extra long V-Anvil (Ø10 - Ø100) (for 250RS, 400RS, 400RS-IMP & 651RS)	CM-08-0186		
5	Fixtures & Vices	A	Polished precision vice with lock down system, jaw width 25mm, open's 20mm	UN-VICE/210		
		B	Polished precision vice with lock down system, jaw width 36mm, open's 42mm	UN-VICE/215		
		C	Polished precision vice with lock down system, jaw width 48mm, open's 75mm	UN-VICE/220		
		D	Polished precision vice with lock down system, jaw width 75mm, open's 100mm	UN-VICE/230		
		E	V groove clamp for small round parts dia.0.8-5mm	UN-VGROOVE- CLAMP		
		F	Wire Testing Fixture for specimen dia 0.8-3.5mm	UN-WIRE/105		
		G	Small parts vice jaw width 55mm, open 50mm, self centering	UN-VICE/115		
		H	Motorized CNC slider for UN-JOMFIX1 (for 400RS-IMP)	UN-XCNCJOMFIX1		
		I	Jack Rest (for 250RS, 400RS, 400RS-IMP & 652RS-IMP)	SA-08-0010		
		J	Adjustable Vari rest (for 250RS, 400RS & 400RS-IMP)	SA-08-0013		
6	Test tables		Testing table flat ø180mm, screwfix (for 250RS, 400RS & 400RS-IMP)	ASV700-00-20		
			Testing table flat ø200mm, screwfix (for 651RS)	UN-TESTTABLE/010		
			Testing table flat ø235mm, screwfix (for 651RS)	UN-TESTTABLE/012		
			Testing table flat ø235mm, screwfix (for 250RS, 400RS & 400RS-IMP)	UN-TESTTABLE/014		
			Testing table ø200mm (61 - 65HRC) requires lock flange (for 250RS, 400RS, 400RS-IMP & 651)	CM-08-0194		
			Clamping, locking & fixing adapters	Lock flange	ASV700-21-01	
				Lock flange	AS9000-21-01	
		7	Machine stands	A	Cabinet test table with drawer for hardness testers 71x75x70cm	UN-STAND/950
					Cabinet test table with drawer for hardness testers 71x90x57cm	UN-STAND/955
					Cabinet test table with drawer for hardness testers 71X90X42cm	UN-STAND/956
	Cabinet test table with drawer for hardness testers 71x75x80cm			UN-STAND/960		
		B	Cabinet test table with drawer for hardness testers 150x75x80cm	UN-STAND/965		

# ORDER DETAILS

## ACCESSORIES

	Seaworthy packing box for 950/960	PACK/100	
	Seaworthy packing box for 955/956	PACK/150	
	Seaworthy packing box for 965	PACK/200	
Covers	Machine cover 600x700x1000mm (for 651RS & 652RS-IMP)	UN-COVER05	
	Machine cover 350x550x870mm (for 400RS & 400RS-IMP)	UN-COVER02	
	Machine cover 350x550x770mm (for 250RS)	UN-COVER01	
ISO / ASTM verification	ROCKWELL direct and indirect verification/calibration & certification in compliance with ISO & ASTM, NADCAP. Includes direct force and indirect verification report (block readings), GR & R report, flat fee for selected common scales, per scale.	CALCEFRDW/1R	
	BRINELL direct and indirect verification/calibration & certification in compliance with ISO & ASTM, NADCAP. Includes direct force and indirect verification report (block readings), GR & R report, flat fee for selected common scales, per scale.	CALCEFRDW/1B	
Joystick	3-axis joystick, with fine adjustment and dynamic axis control	UN-JOYSTICK1	<b>STANDARD</b> 651RS 652RS-IMP

## SOFTWARE

Software	Force depth/time diagram (for 400RS-IMP & 652RS-IMP)	UN-FDDIAGR	<b>STANDARD</b> 400RS-IMP 652RS-IMP
	User level management (for 400RS-IMP & 652RS-IMP)	UN-LEVMAN	<b>STANDARD</b>
	Advanced communication protocol for robotic systems (for 400RS-IMP & 652RS-IMP)	UN-REMC	
Connectivity plus	Q-DAS Certified connectivity protocol (for 651RS & 652RS-IMP)	UN-QDAS	
	Wireless system Keyboard & wireless mouse (for 400RS-IMP & 652RS-IMP)	UN-SKBSET	<b>STANDARD</b>
	Interface cable for PC (for 250RS, 400RS, 400RS-IMP & 651RS)	UN-CABLE/910	
	USB to USB null modem cable 2.5M (for 400RS-IMP & 652RS-IMP)	BE-99-0025	
	Utility software; Import test results in MS applications like Excel	UN-SW/905	
	Bluetooth connectivity (for 400RS-IMP & 652RS-IMP)	UN-BTADAPT	
	Laser Printer (for 400RS-IMP & 652RS-IMP)	UN-PRINT	
Upgrades	Upgrade Rockwell tester RS to RSB, Brinell scales, analogue microscope 40x (for 250RS, 400RS, 400RS-IMP & 652RS-IMP)	UN-BPACK01	
	Upgrade Rockwell tester RS to RSB, Brinell scales, BIOS 1 for indents 1.6mm to 6mm made with 5mm or 10mm ball indenter - USB3 (for 400RS-IMP & 652RS-IMP)	UN-BPACK06	
	Upgrade Rockwell tester RS to RSB, Brinell scales, BIOS 2 for indents 0.5mm to 1.5mm made with 1mm or 2.5mm ball indenter - USB3 (for 400RS-IMP & 652RS-IMP)	UN-BPACK07	



MOTORIZED

**JOMINY STAGE**

# ACCESSORIES

## MICROSCOPE

UN-BPACK



AS3001-MICRO/02

## SCANNERS

UN-BPACK



SA-12-0001



SA-12-0002

## INDENTERS



## CLAMP & INSERTS



SA-02-0110



## ANVILS



## FIXTURES & VICES



## TEST TABLES



ASV700-00-20  
UN-TESTTABLE/010  
UN-TESTTABLE/012  
UN-TESTTABLE/014  
CM-08-0194

## MACHINE STANDS





UN-STAND/950



UN-STAND/965

# SPECIFICATIONS

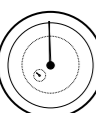

TEST FORCE			HAWK 250RS	HAWK 400RS	HAWK 400RS-IMP	HAWK 651RS	HAWK 652RS-IMP
	<b>TEST FORCES</b>	1kgf - 187.5kgf	+	+	+	3kgf - 150kgf	+
	<b>FORCE APPLICATION</b>	Load cell, closed loop, force feedback system	+	+	+	+	+
HARDNESS SCALES							
	<b>ROCKWELL</b>	Regular Rockwell scales; Pre Load 10kgf, Main Load 60kgf   100kgf   150kgf A   B   C   D   E   F   G   H   K   L   M   P   R   S   V Superficial Rockwell scales; Pre Load 3kgf, Main Load 15kgf   30kgf   45kgf 15N   30N   45N   15T   30T   45T   15W   30W   45W   15X   30X   45X   15Y   30Y   45Y	+	+	+	+	+
	<b>BRINELL</b>	HBW1/1   HBW1/1.25   HBW1/2.5   HBW1/5   HBW1/10   HBW1/30 HBW2.5/6.25   HBW2.5/7.8125   HBW2.5/15.625   HBW2.5/31.25   HBW2.5/62.5   HBW2.5/187.5 HBW5/25   HBW5/31.25   HBW5/62.5   HBW5/125	Optional	Optional	Optional	—	Optional
	<b>PLASTIC ISO 2039</b>	49 N, 132 N, 358 N, 961 N	+	+	+	+	+
	<b>ASTM D785</b>	For plastics and electric insulation materials	+	+	+	+	+
	<b>HVD (HVT)</b>	HV5   HV10   HV20   HV25   HV30   HV40   HV50   HV60   HV100   HV120   HV125   HV150	+	+	+	+	+
	<b>HBD (HBT)</b>	HB1/5   HB1/10   HB1/30 HB2.5/6.25   HB2.5/7.8125   HB2.5/15.625   HB2.5/31.25   HB2.5/62.5   HB2.5/187.5 HB5/25   HB5/31.25   HB5/62.5   HB5/125	+	+	+	+	+
	<b>CARBON</b>	HR 2.5/7   HR 5/7   HR 5/15   HR 5/20   HR 5/40   HR 5/60   HR 5/100   HR 5/150	+	+	+	+	+
	<b>VICKERS (indentation only)</b>	HV1   HV2   HV2.5   HV3   HV4   HV5   HV10   HV20   HV25   HV30   HV40   HV50   HV100   HV120   HV150	Optional	Optional	Optional	—	Optional
	<b>KNOOP (indentation only)</b>	HK1   HK2   HK2.5   HK3   HK4   HK5	Optional	Optional	Optional	—	Optional
SYSTEM							
	<b>I-TOUCH™</b>	Graphic User Interface, Full color touchscreen, USB-2	+	+	—	+	—
	<b>IMPRESSIONS™ MT</b>	Integrated system controller, Windows 10, 8,5" full color touchscreen, LAN, W-LAN, USB-3	—	—	+	—	—
	<b>IMPRESSIONS™</b>	Integrated system controller, Windows 10, 15" full color touchscreen, LAN, W-LAN, USB-3	—	—	—	—	+
GENERAL							
	<b>Z-AXIS</b>	Motorized Z-axis	—	Optional	Optional	+	++ / Dual
	<b>MACHINE DIMENSIONS</b>		360 x 600 x 765mm	360 x 600 x 915mm	360 x 600 x 915mm	535 x 740 x 1255mm	535 x 740 x 1255mm
	<b>MACHINE WEIGHT</b>		120 kg	140 kg	140 kg	247 kg	265 kg
	<b>TEST FORCE TOLERANCE</b>	< 0.5%	+	+	+	+	+
	<b>DWELL TIME SETTINGS</b>	Default 4 seconds, user defined. Up to 999 seconds	+	+	+	+	+
	<b>OPERATING TEMPERATURE</b>	10°C to 35°C	+	+	+	+	+
	<b>POWER CONSUMPTION</b>	<100W	+	+	+	+	+
	<b>HUMIDITY</b>	10% to 90%, non-condensing	+	+	+	+	+

# TECHNICAL DRAWINGS

All dimensions in these drawings are in mm, approximate. Working heights and or workpiece accommodation varies depending on the stages and stage accessories used.

Please contact our sales department for more details.

## HAWK 250RS

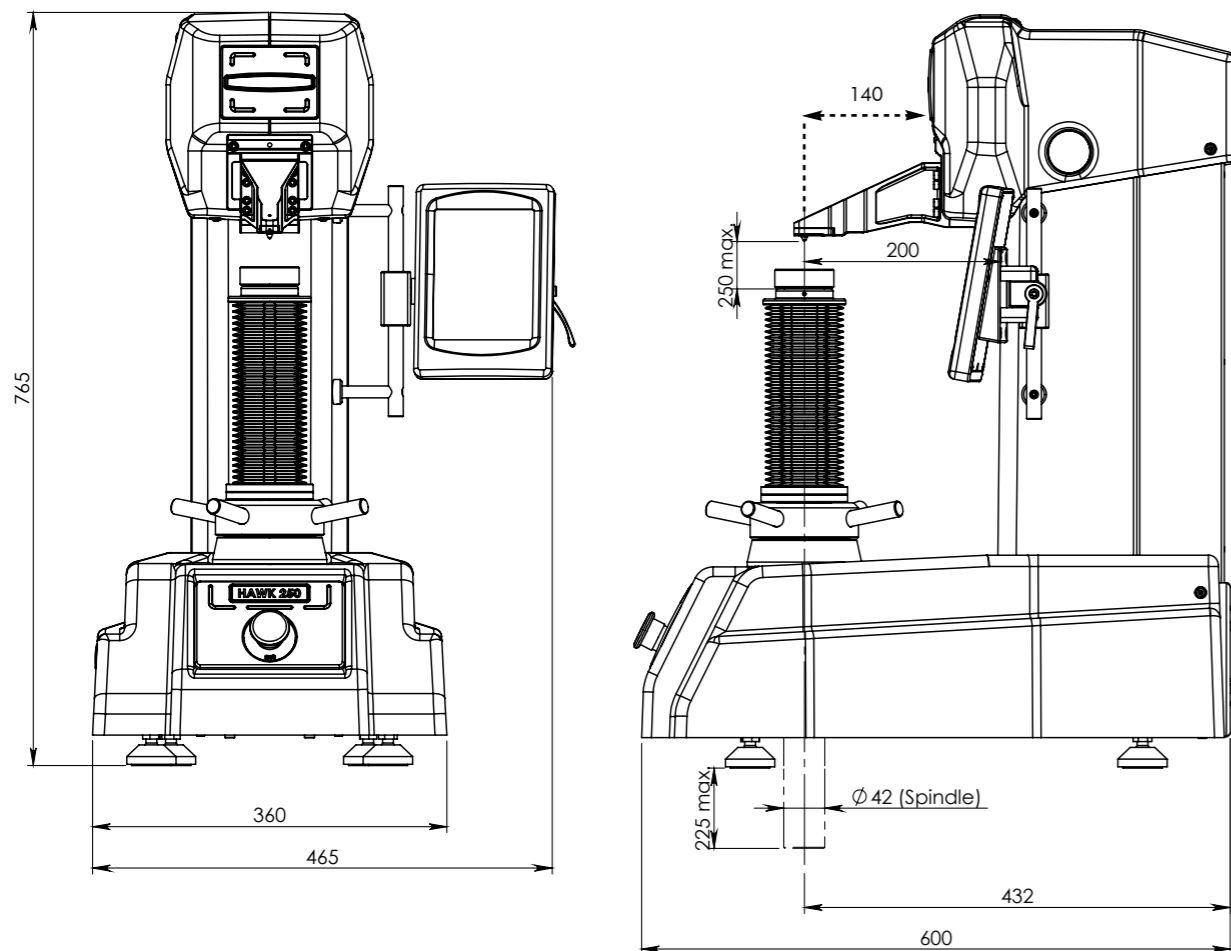

## HAWK 400RS

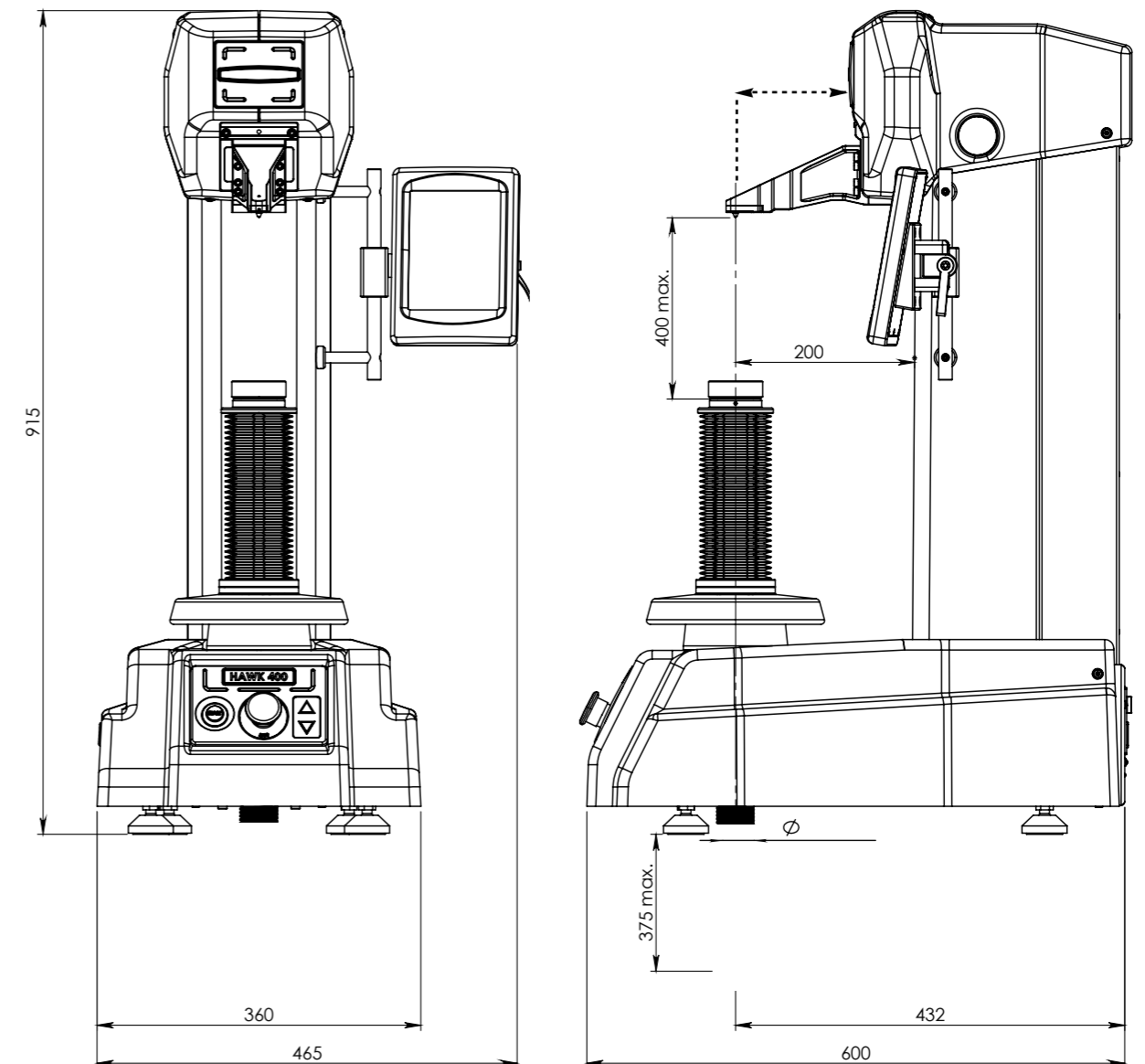

# TECHNICAL DRAWINGS

All dimensions in these drawings are in mm, approximate. Working heights and or workpiece accommodation varies depending on the stages and stage accessories used.

Please contact our sales department for more details.

## HAWK 651RS

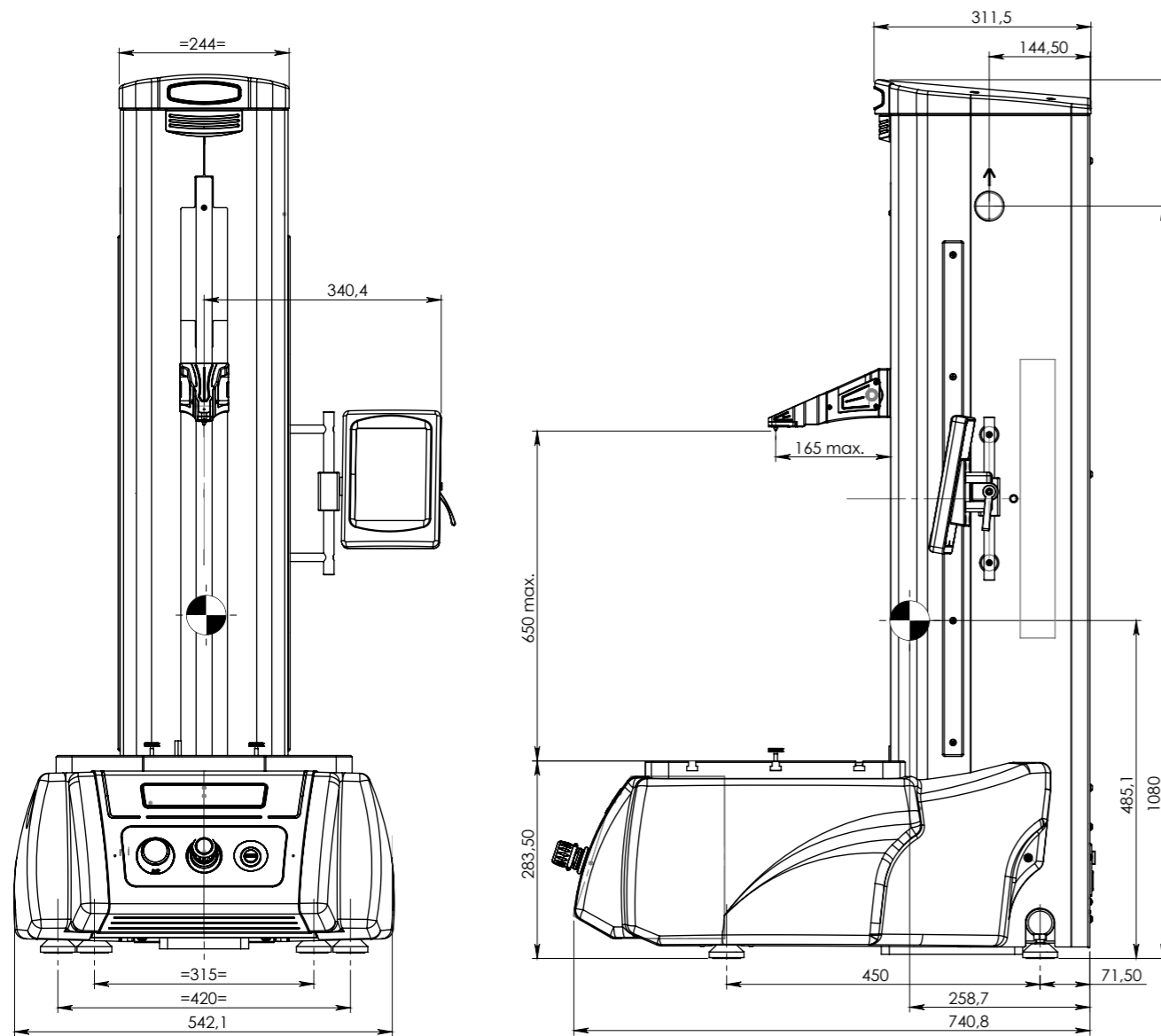

## HAWK 652RS-IMP

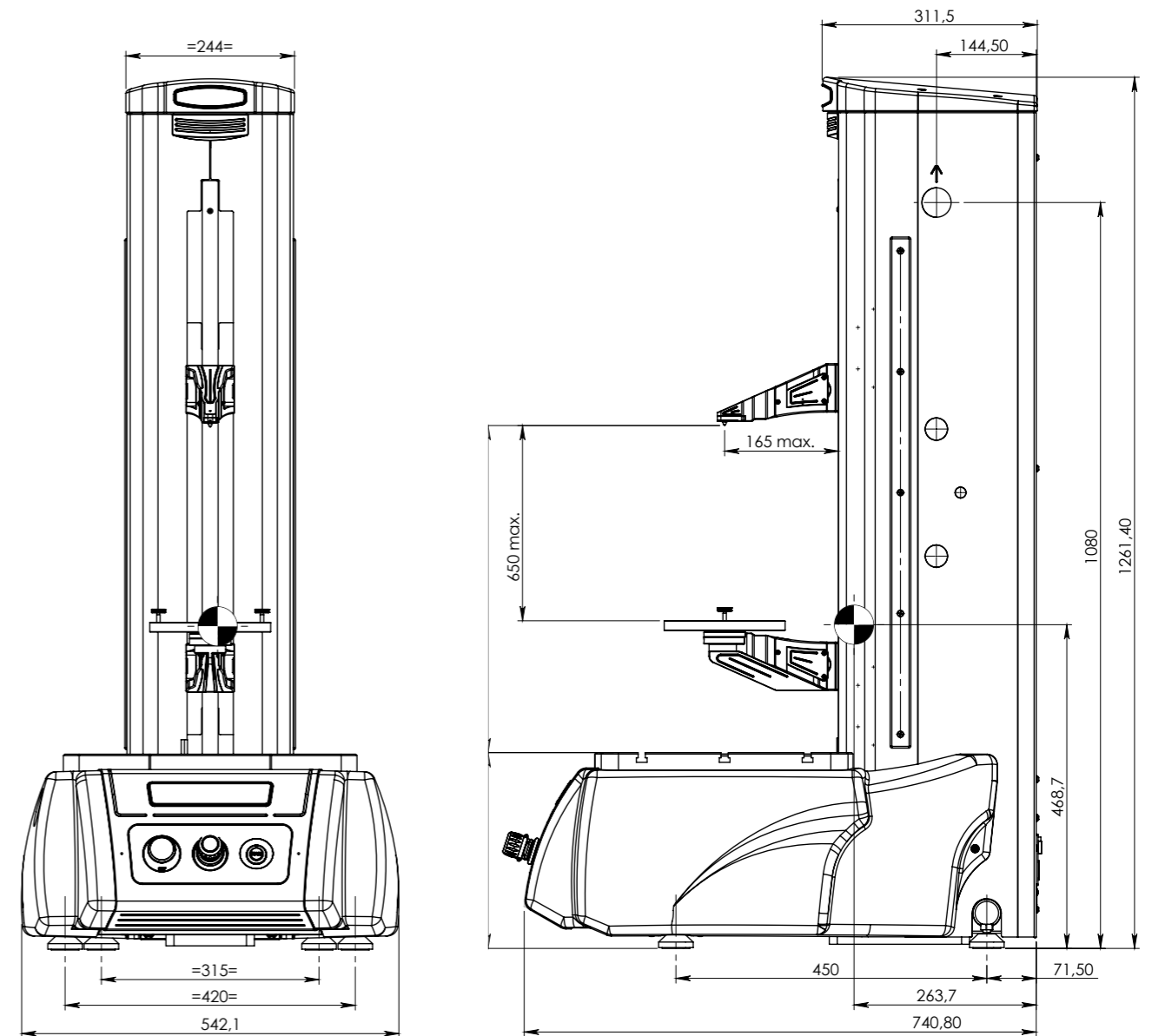

## OTHER MODELS IN THE ROCKWELL RANGE



### FENIX 200AR

Load applied from a dead weight force actuator Rockwell / Brinell hardness tester.

See brochure B18F200/XX



### FENIX 200ACL

Load Cell, closed loop, force feedback, test force application system Rockwell / Brinell hardness tester.

See brochure B18F200/XX



### FENIX 200DCL

Load Cell, closed loop, force feedback, test force application system Rockwell / Brinell hardness tester.

See brochure B18F200DCL/XX



### VERZUS 720

Load Cell, closed loop Rockwell/Superficial Rockwell/ Brinell hardness tester, with direct depth measuring system, integrated PC, Windows 10, wifi, full color touchscreen.

See brochure B18V720/XX



### NEMESIS 6100

Load Cell, Closed loop Fully automatic Rockwell/ Superficial Rockwell (Brinell) hardness tester with descending test head & fixed workpiece position.

See brochure B18N6100/XX



### NEMESIS 6200

Load Cell, Closed loop Fully automatic Rockwell/ Superficial Rockwell (Brinell) hardness tester with descending test head & fixed workpiece position, integrated PC, Windows 10, Wifi, full color 15" industrial capacitive touchscreen.

See brochure B18N6200/XX



### FENIX 300RS

Load Cell, closed loop, force feedback, test force application system Rockwell / Brinell hardness tester with I-TOUCH™ system.

See brochure B20F300/XX



### FENIX 300RS-IMP

Load Cell, closed loop, force feedback, test force application system Rockwell / Brinell hardness tester with IMPRESSIONS™ system.

See brochure B20F300/XX



### FENIX 300XL

Load Cell, closed loop, force feedback, test force application system Rockwell / Brinell hardness tester.

Extra tall working height  
See brochure B20F300/XX



### NEMESIS 9100RS

Heavy duty, Load Cell, closed loop Rockwell/Superficial Rockwell/ Brinell hardness tester, with integrated PC, Windows 10, WiFi etc.

full color touchscreen.  
See brochure B18N9100/XX

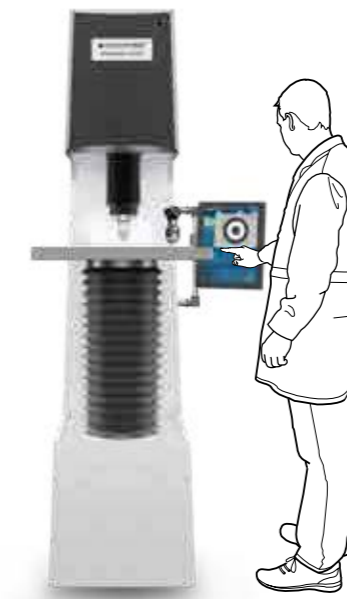

### NEMESIS 9600RSB

Floor type, Load Cell, closed loop. Brinell, Rockwell, Superficial Rockwell Hardness tester with motorized Z-axis & BIOS Brinell Indent Optical Scanner

See brochure B19N9600/XX

Changes in products and/or product specifications can emerge due to new technologies and continuous development.

We reserve the right to change or modify specifications of the products without prior notice. We recommend you to contact our sales office for up-to-date information.

Brochure B20HSERIES/06/EN

Distributor :

## **CORPORATE HEAD OFFICE**

### **INNOVATEST Europe BV**

**Manufacturing, Distribution & Service**

Borgharenweg 140  
6222 AA MAASTRICHT  
The Netherlands

Phone: +31 43 3520060

Fax: +31 43 3631168

[info@innovatest-europe.com](mailto:info@innovatest-europe.com)

[www.innovatest-europe.com](http://www.innovatest-europe.com)

#### **INNOVATEST Deutschland GmbH Sales & Service**

Phone: +49 245 670 59 500  
[info@innovatest-deutschland.com](mailto:info@innovatest-deutschland.com)  
[www.innovatest-deutschland.com](http://www.innovatest-deutschland.com)

#### **INNOVATEST France SARL Sales & Service**

Phone: +33 1848 88038  
[info@innovatest-france.com](mailto:info@innovatest-france.com)  
[www.innovatest-france.com](http://www.innovatest-france.com)

#### **INNOVATEST USA Company Sales & Service**

Phone: +1 267 317 4300  
[info@innovatest-usa.com](mailto:info@innovatest-usa.com)  
[www.innovatest-usa.com](http://www.innovatest-usa.com)

#### **INNOVATEST Japan K.K. Sales & Service**

Phone: +81 3 6667 0554  
[info@innovatest-japan.com](mailto:info@innovatest-japan.com)  
[www.innovatest-japan.com](http://www.innovatest-japan.com)

#### **INNOVATEST UK Ltd. Sales & Service**

Phone: +44 121 274 0105  
[info@innovatest-uk.com](mailto:info@innovatest-uk.com)  
[www.innovatest-uk.com](http://www.innovatest-uk.com)

#### **INNOVATEST Polska sp. z.o.o Sales & Service**

Phone: +48 697 099 826  
[info@innovatest-polska.pl](mailto:info@innovatest-polska.pl)  
[www.innovatest-polska.pl](http://www.innovatest-polska.pl)

#### **INNOVATEST Shanghai Co., Ltd. Sales & Service**

Phone: +86 21 60906200  
[info@innovatest-shanghai.com](mailto:info@innovatest-shanghai.com)  
[www.innovatest-shanghai.com](http://www.innovatest-shanghai.com)

#### **INNOVATEST South East Asia Sales & Service**

Phone: +65 6451 1123  
[info@innovatest-singapore.com](mailto:info@innovatest-singapore.com)  
[www.innovatest-singapore.com](http://www.innovatest-singapore.com)