

FENIX 200 SERIES

Rockwell | Brinell Hardness Testers

MANUAL & SEMI-AUTOMATIC



FENIX 200AR

Fast & affordable Rockwell testing...

Quality long life mechanics, readings from a precision analogue indicator. Load applied from a dead weight force actuator, with solid test load selector design. The newly designed C frame made out of steel (no casting) provides 100% more rigidity compared to traditional casted designs and assures excellent results, even after years of use.

The internal system can be easily serviced by removing the side and top covers, no need to turn the machine around.



HARDNESS SCALES



ROCKWELL 10kgf – 150kgf



ROCKWELL FORCE RANGE

1kgf	10kgf	FENIX 200AR	150kgf	187.5kgf
------	-------	-------------	--------	----------

HIGHLIGHTS

- 1 Rockwell scales : A | B | C | D | E | F | G | H | K | L | M | P | R | S | V
- 2 Test loads: pre-load : 10kgf, main-load : 60 | 100 | 150kgf
- 3 Adjustable hydraulic force speed damper
- 4 Adjustable dial indicator with 0.5 HR Rockwell units
- 5 Throat depth : 150mm
- 6 Working height : 260mm
- 7 Rockwell ISO 6508, ASTM E18
- 8 Machine weight (net) : 122kg
- 9 Machine dimensions : H765mm / W270mm / D555mm

FENIX 200ACL

Affordable Rockwell testing, re-invented...

A load cell, closed loop, force feedback, test force application system that is absolutely unique in this class of instruments. Limited mechanical structure, without weights or weight selection. Hardness scales can be selected on the digital display. Conduct Rockwell hardness testing with great force precision and without the disadvantage of a relative complex mechanical dead weight system.

The internal system can be serviced by removing the side and top covers, no need to turn the machine around.



HARDNESS SCALES	
	ROCKWELL 10kgf – 150kgf
	BRINELL 10kgf – 187.5kgf



TECHNOLOGY OF TODAY

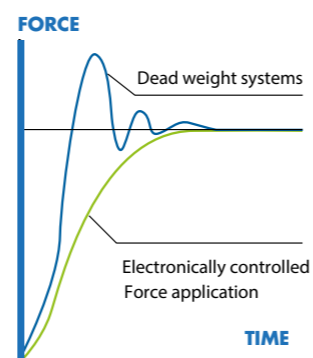

Load cell, closed loop, force feedback system

ROCKWELL & BRINELL FORCE RANGE

1kgf	10kgf	FENIX 200ACL	187.5kgf
------	-------	--------------	----------

HIGHLIGHTS

- 1 Load cell, closed loop, force feedback, force application system, error <0,25%
- 2 Rockwell scales : A | B | C | D | E | F | G | H | K | L | M | P | R | S | V
Brinell scales : HBW1/30 | HBW2.5/31.25 | HBW2.5/62.5 | HBW2.5/187.5 HBW5/25
HBW5/62.5 | HBW5/125 | HBW10/100
- 3 Digital display for scale indication, dwell time count down.
- 4 Start/stop & menu selection buttons.
- 5 Adjustable dial indicator with 0.5 HR Rockwell units
- 6 Throat depth : 150mm
- 7 Working height : 260mm
- 8 Machine weight (net) : 104kg
- 9 Machine dimensions : H765mm / W270mm / D555mm

SENSIBLE

INNOVATION

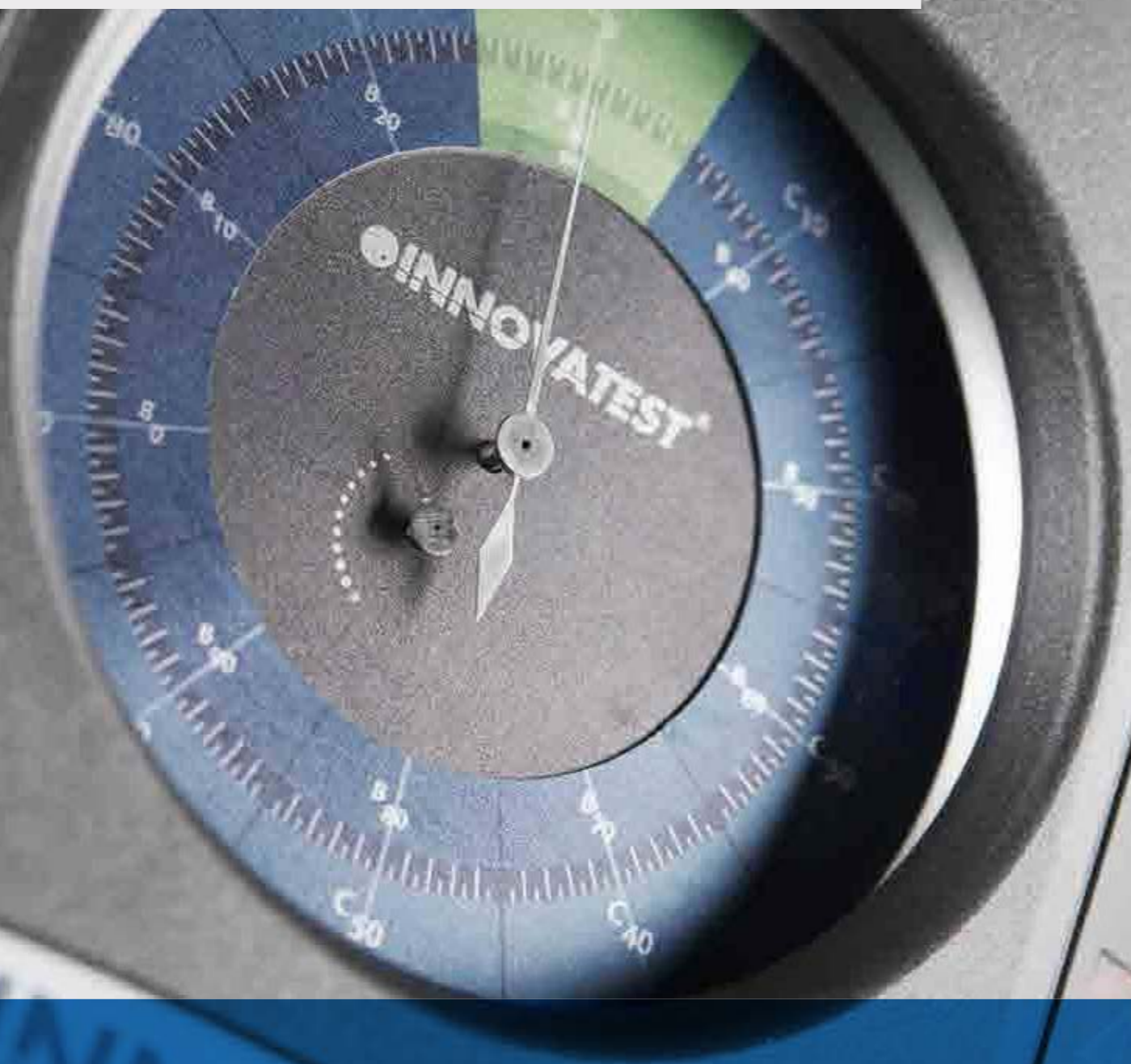

200ACL
Multi loadcell,
ball bearing,
force actuator



STANDARD
Force
adjustable
workpiece clamp

Observe, Think, Try, Change...

Unparalleled in this class of Rockwell hardness testing machines is the electronic Load cell, closed loop, force feedback, force application system. Absolute maintenance free, automatic setting of test forces by choosing the Rockwell hardness scale. Error free operation, due to an automatic test cycle, applying the main load and correct pre-set dwell time.



VARIOUS POSSIBILITIES

The FENIX 200 is larger than most other machines in its class. With a throat depth of 150mm and maximum workpiece height of 260mm, it offers the user a generous workspace. Moreover the FENIX 200 is super rigid, sturdy and can withstand the harshest environments. Compare these parameters with alternative products and find that FENIX is leading in its class.



INDENTER COVER & CLAMP

The FENIX 200 series is standard equipped with an indenter protection cover that includes an integrated spring loaded workpiece clamp pressing the workpiece firmly on the anvil and eliminating possible workpiece and spindle hysteresis. Adjustable clamp force, to avoid impressions on softer materials.



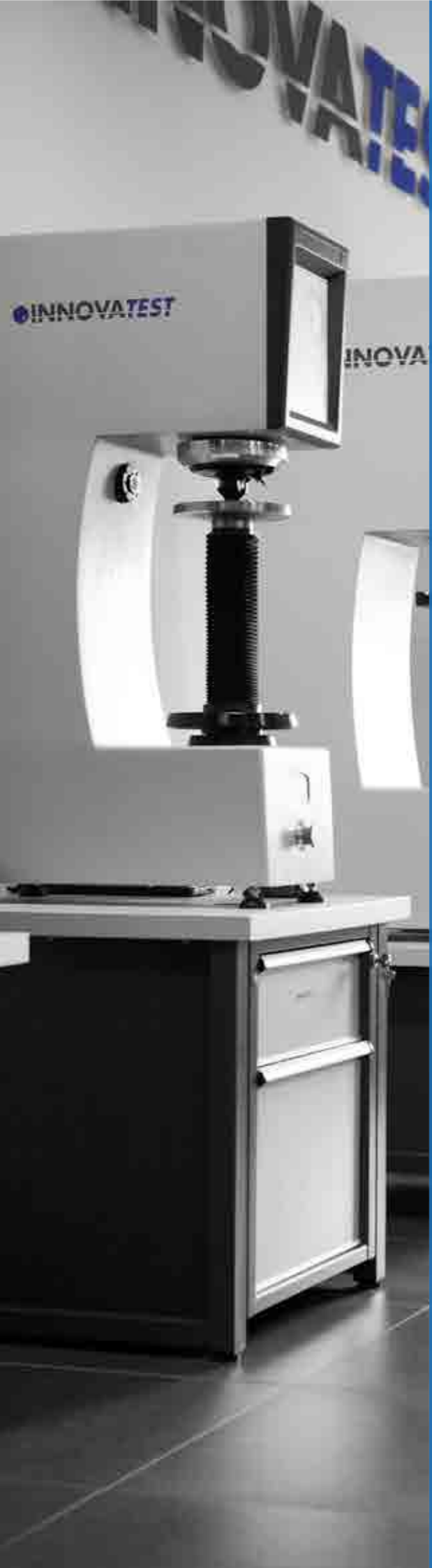

SUPPORT YOUR BEST TESTING RESULTS

With our rigid designed Bench stands

- Rock solid bench stands
- 100% retractable drawer, bearing guidance, max 100kg load. Rubber anti slip bottom
- Lockable cabinet, 300mm high
- Adjustable feet, (+/- 50mm height adjustable to reach ergonomic working position)
- Made of corrosion resistant zinc plated steel with RAL powder coating
- Carrying capacity of 400kg
- Top surface made of 50mm Plywood with 1.5mm chemical resistant plastic plating, edges made of shock resistant 3mm ABS side liner
- Industrial quality, for workshop or laboratory

Designed for hardness testing instruments, painted in INNOVATEST® RAL colors matching our testers.



UN-STAND/960 71 x 75 x 80 cm



UN-STAND/965 150 x 75 x 80 cm

ACCESSORIES

FENIX 200

Schematic overview of the configuration options, standard and optional accessories

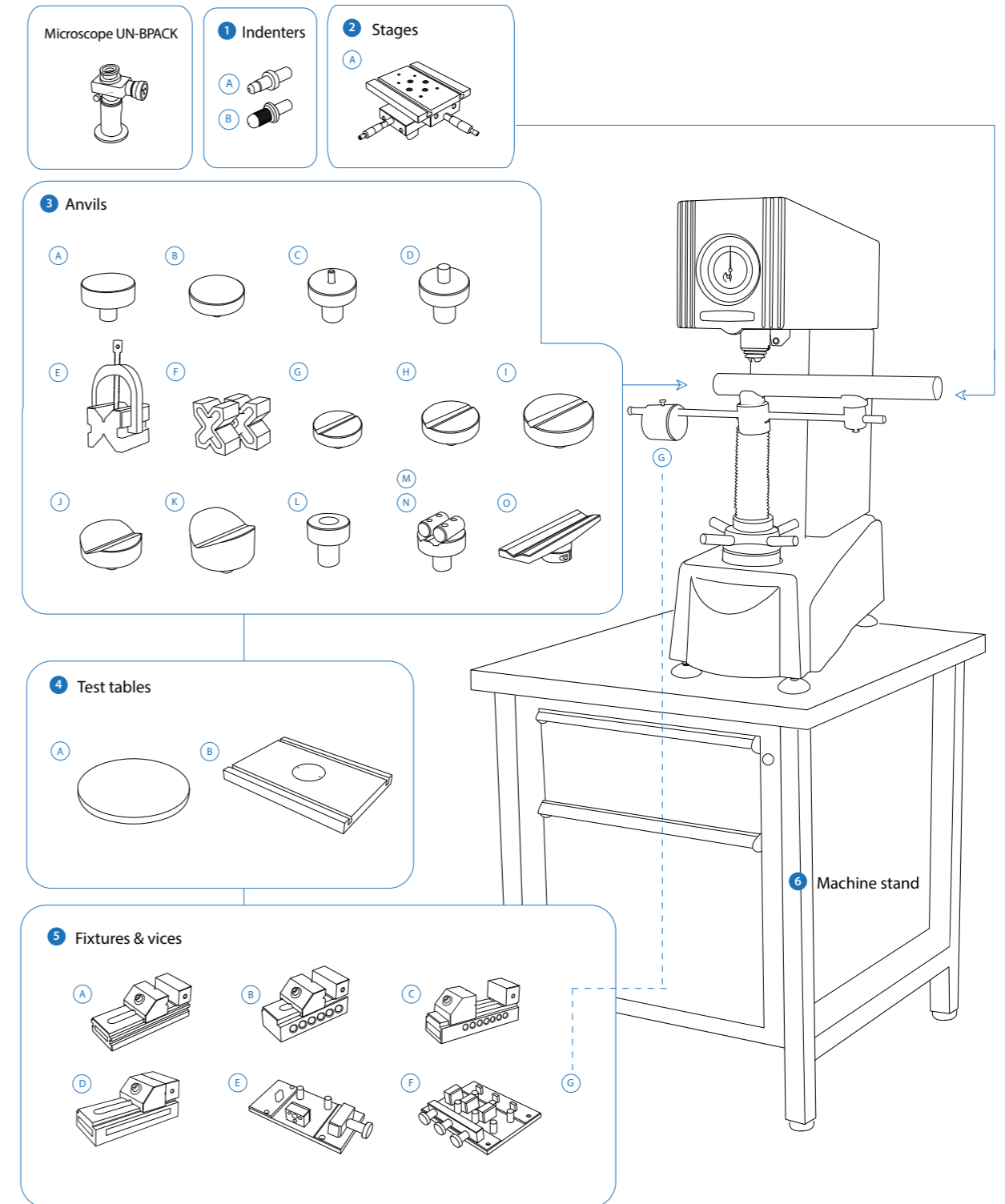

Not all accessories are displayed on this page. Full details can be found on the Order details page.

ORDER DETAILS

FENIX 200



Analogue, manual, Rockwell hardness tester 10kgf - 150kgf	FENIX 200AR	
Analogue, Load Cell Closed Loop, Rockwell hardness tester 10kgf - 187.5kgf	FENIX 200ACL	
Plug & Play prepared, calibration, sea & airworthy packing in "non coniferous wood" material	P&PSEAPACK60	

ACCESSORIES

1	Indenters	A	Rockwell C Diamond Indenter. Ø6.35mm. ISO & ASTM certified	IN/6005				
			Rockwell Ball Indenter 1/16". Includes 1 carbide ball. Ø6.35mm. ISO & ASTM certified	IN/7506				
			Rockwell Ball Indenter 1/8". Includes 1 carbide ball. Ø6.35mm. ISO & ASTM certified	IN/7606				
			Rockwell Ball Indenter 1/4". Includes 1 carbide ball. Ø6.35mm. ISO & ASTM certified	IN/7706				
			Rockwell Ball Indenter 1/2". Includes 1 carbide ball, Ø6.35mm. ISO & ASTM certified	IN/7806				
			B	Brinell Indenter 1mm. Includes 1 carbide ball. Ø6.35mm. ISO & ASTM certified	IN/7000			
				Brinell Indenter 2.5mm. Includes 1 carbide ball. Ø6.35mm. ISO & ASTM certified	IN/7005			
				Brinell Indenter 5mm. Includes 1 carbide ball. Ø6.35mm. ISO & ASTM certified	IN/7010			
				Brinell Indenter 10mm. Includes 1 carbide ball. Ø6.35mm. ISO & ASTM certified	IN/7015			
			2	Stages		Manual X-Y stage with analogue metric micrometers, 180x160mm Displacement: 25x25mm, scale 0.01mm, max load 300kg	UN-TESTTABLE/030	
3	Anvils	A	Flat anvil 60mm	AS3000-19-04				
			B	Flat anvil 80mm	UN-TESTTABLE/002			
			C	Spot anvil 5mm	UN-ANVIL/010			
			D	Spot anvil 10mm	UN-ANVIL/011			
			E	V block with bracket 40x40x50mm (LxBxH)	UN-VBLOCK404050			
			F	Steel, cross type, (X) V-block 60x120x100mm 8-90mm pair	UN-CROSSBLOCK01			
			G	V-anvil ø40mm 6-60mm	UN-ANVIL/005			
			H	V-anvil ø63mm 10-100mm	UN-ANVIL/006			
			I	V-Anvil ø80mm 3.3-20mm	UN-ANVIL/040			
			J	V-Anvil ø80mm 15-80mm	UN-ANVIL/045			
			K	V-Anvil ø80mm 23-40mm	UN-ANVIL/050			
			L	Anvil for round specimen dia. 6-25,4mm	UN-ANVIL/200			
			M	Cylindrical V anvil 6-80mm	UN-CVANVIL680			
			N	Cylindrical V anvil 50-200mm	UN-CVANVIL50200			
			4	Test Tables	A	Test table 100x100mm, V groove 20mm wide, 10mm deep	UN-TESTTABLE/040	
						Extra long V-Anvil (Ø10 - Ø100)	CM-08-0186	
Testing table Ø200mm (61 - 65HRC) requires lock flange	CM-08-0194							
Testing table flat ø180mm, screwfix	ASV700-00-20							
Testing table flat ø235mm, screwfix	UN-TESTTABLE/014							
B	Large flat surface testing table 350x250mm, thickness 30mm with 2 T-slots, for large components	UN-TESTTABLE/015						

5	Fixtures and Vices	A	Lock flange	UN-XYZ BUSH42		
			Mounting plate for lock flange	UN-XYZ30FP40-42		
			Lock flange	ASV700-21-01		
			B	Polished precision vice with lock down system, jaw width 25mm, opens 20mm	UN-VICE/210	
			C	Polished precision vice with lock down system, jaw width 36mm, opens 42mm	UN-VICE/215	
			D	Polished precision vice with lock down system, jaw width 48mm, opens 75mm	UN-VICE/220	
			E	Polished precision vice with lock down system, jaw width 75mm, opens 100mm	UN-VICE/230	
6	Machine Stand	F	JOMINY Fixture, for 1 quench end test sample, quick release function	UN-JOMFIX1		
			G	JOMINY Fixture, for 3 quench end test sample, quick release function	UN-JOMFIX3	
			G	Adjustable Vari rest	SA-08-0013	
			Machine Stand	Cabinet test table with drawer for hardness testers 71x75x80cm	UN-STAND/960	
				Seaworthy packing box for 950/960	PACK/100	
			ISO/ASTM verification	Direct and Indirect Verification/Calibration & BRINELL Certification in compliance with ISO & ASTM, NADCAP. Includes Direct force and depth verification report, machine hysteresis report, indirect verification report (block readings), GR & R report, flat fee for selected common scales, per scale	CALCEFRDW/1B	
	Direct and Indirect Verification/Calibration & ROCKWELL Certification in compliance with ISO & ASTM, NADCAP. Includes Direct force and depth verification report, machine hysteresis report, indirect verification report (block readings), GR & R report, flat fee for selected common scales, per scale	CALCEFRDW/1R				

SOFTWARE

Upgrades	Upgrade Rockwell tester RS to RSB, Brinell scales, analogue microscope 40x (for 200ACL)	UN-BPACK01	
----------	---	------------	--

ACCESSORIES

MICROSCOPES

UN-BPACK



AS3001-MICRO/02

INDENTERS

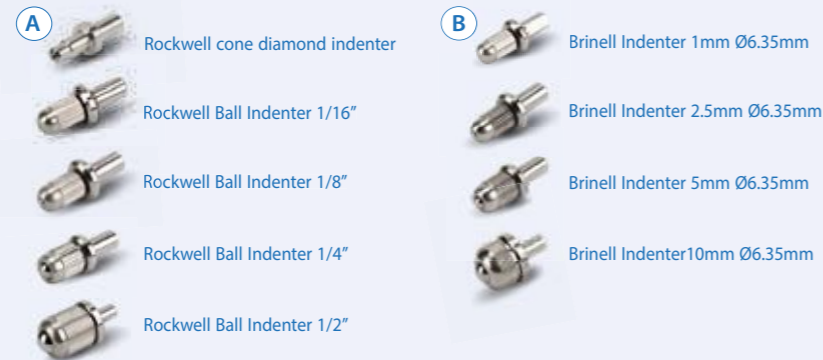

STAGES



UN-TESTTABLE/030

TEST TABLES



CM-08-0194
ASV700-00-20
UN-TESTTABLE/014

UN-TESTTABLE/015

FIXTURES AND VICES



MACHINE STAND



UN-STAND/960

COVER



UN-COVER1

ANVILS



SPECIFICATIONS

HARDNESS SCALES

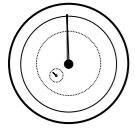
	ROCKWELL ISO 6508, ASTM E18 JIS Z 2245	A B C D E F G H K L M P R S V
	BRINELL* EN-ISO 6506, ASTM E92 JIS Z 2243	HBW1/30 HBW2.5/31.25 HBW2.5/62.5 HBW2.5/187.5 HBW5/25 HBW5/62.5 HBW5/125 HBW10/100 * FENIX 200ACL only

TEST FORCE 200AR

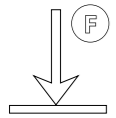
	Force application	Dead weight system via load selector
	Test forces	Preload : 10kgf, main loads : 60 100 150kgf
	Force range	FENIX 200AR 10kgf – 150kgf
	Test force tolerance	< 1% for test force 10kgf to 150kgf
	Dwell time settings	User defined

TEST FORCE 200ACL

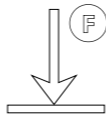
	Force application	Load cell, closed loop, force feedback system
	Test forces	Preload : 10kgf, main loads : 25 30 31.25 60 62.5 100 125 150 187.5kgf
	Force range	FENIX 200ACL 10kgf – 187.5kgf
	Test force tolerance	< 0.25% for test force 10kgf to 187.5kgf
	Dwell time settings	Default 10 seconds, user defined. Up to 999 seconds

GENERAL

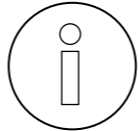
	Machine dimension	765mm x 270mm x 555mm
	Machine weight	FENIX 200ACL: 104kg FENIX 200AR : 122kg
	Workpiece accommodation	150mm (H) x 240mm (D)
	Power supply	FENIX 200ACL: 100VAC to 240VAC, 50/60Hz, single phase
	Operating temperature	10°C to 35°C
	Power consumption	FENIX 200ACL: 10W
	Humidity	10% to 90%, non-condensing



TECHNICAL DRAWINGS

All dimensions in these drawings are in mm, approximate. Working heights and or workpiece accommodation varies depending on the stages and stage accessories used.

Please contact our sales department for more details.

FENIX 200AR

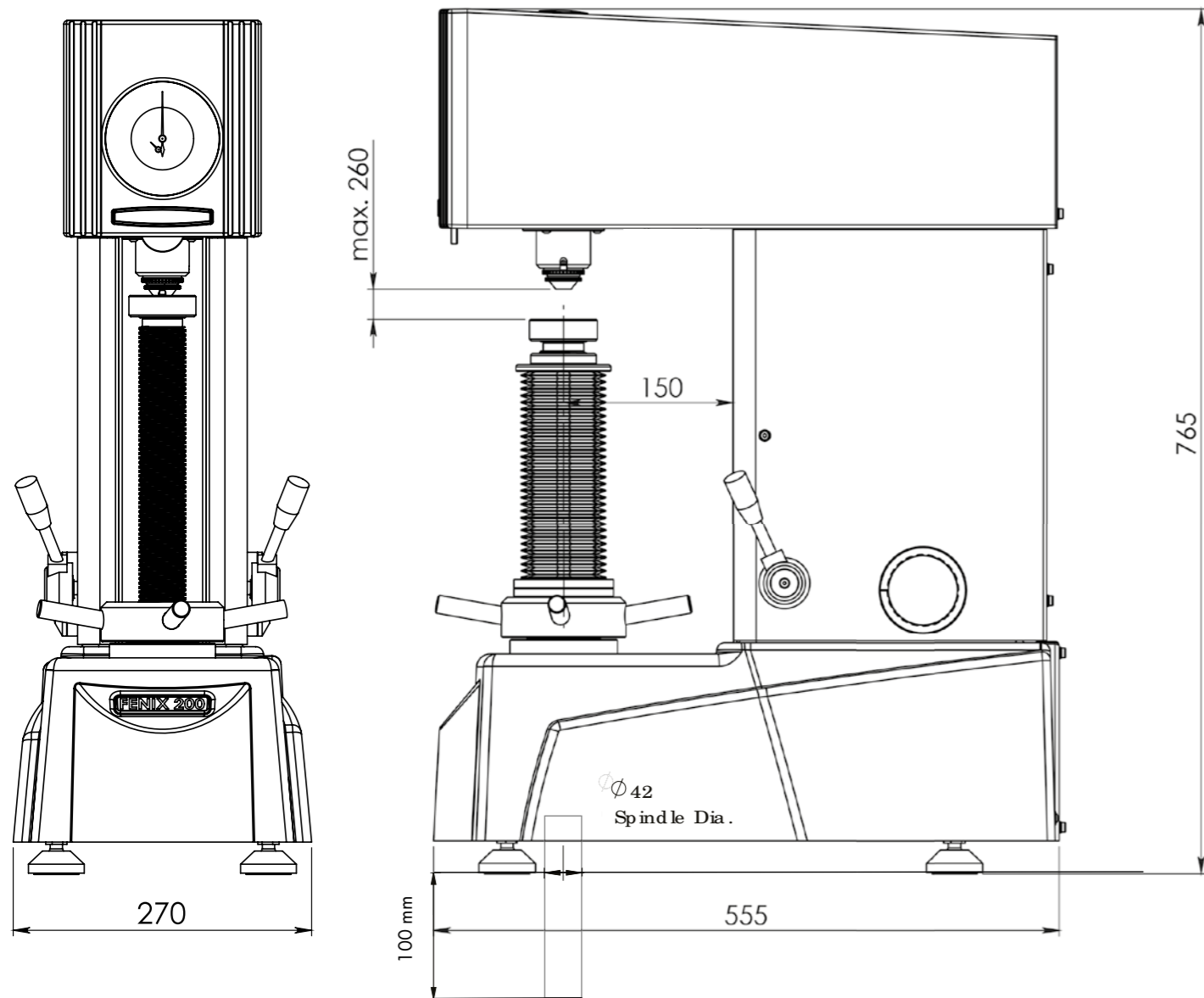

FENIX 200ACL

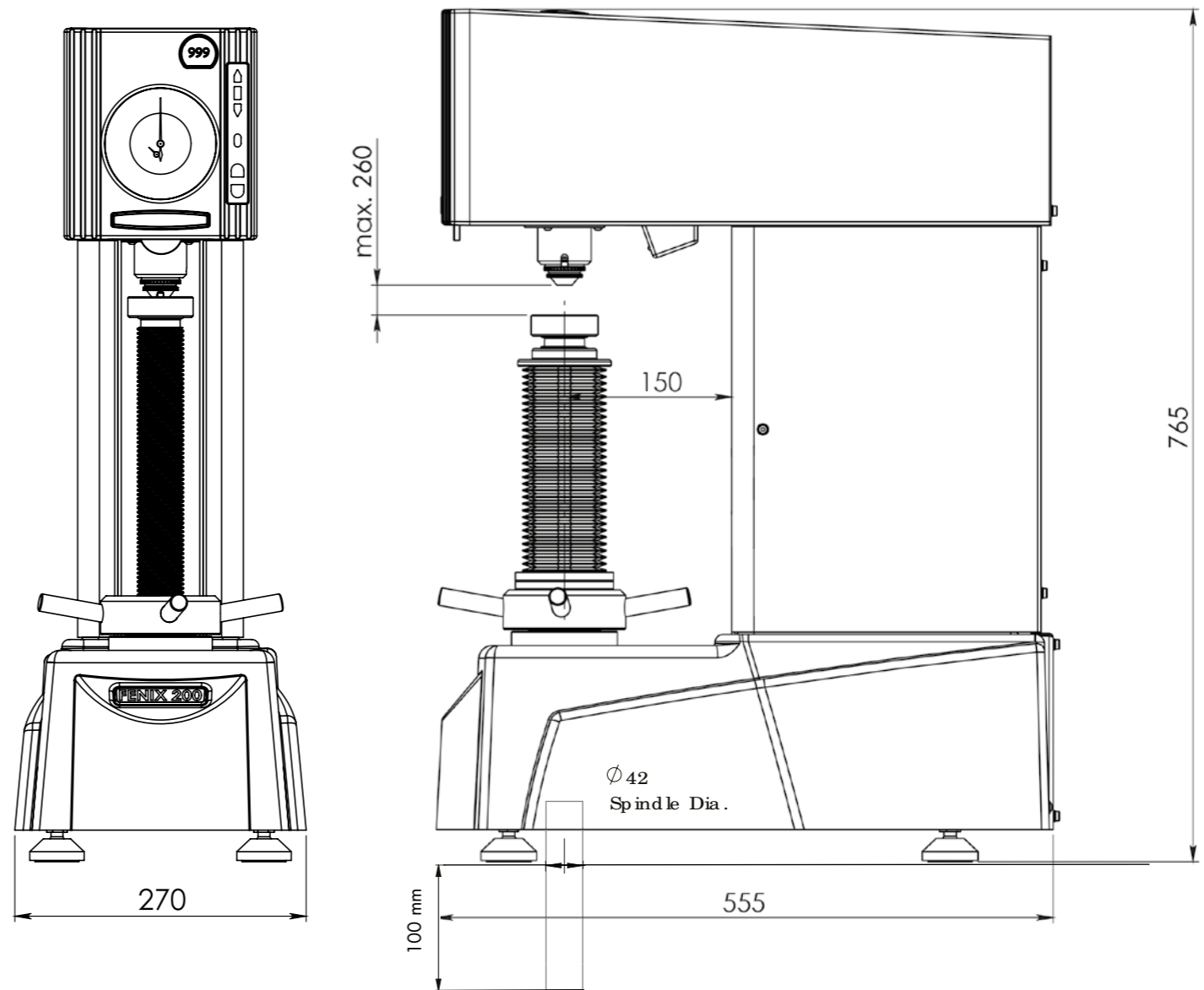



**FAST & AFFORDABLE
ROCKWELL TESTING**

OTHER MODELS IN THE
ROCKWELL RANGE



FENIX 200DCL

Load Cell, closed loop, force feedback, test force application system Rockwell / Brinell hardness tester.
See brochure B18F200DCL/XX



FENIX 300RS

Load Cell, closed loop, force feedback, test force application system Rockwell / Brinell hardness tester with I-TOUCH™ system.
See brochure B20F300/XX



VERZUS 720

Load Cell, closed loop Rockwell/Super Rockwell/ Brinell hardness tester, with direct depth measuring system, integrated PC, Windows 10,WiFi, full color touchscreen.
See brochure B19V720/XX



HAWK 250RS/400RS

Load Cell, closed loop Rockwell/ Superficial Rockwell hardness tester, with direct depth measuring system, Graphic User Interface, 6.5" Full color touchscreen.
See brochure B20HSERIES/XX



HAWK 652RS-IMP

Load Cell, Closed loop Fully automatic Rockwell/ Superficial Rockwell hardness tester with dual motorized Z-Axis, IMPRESSIONS™ software, 15" industrial capacitive touchscreen.
See brochure B20HSERIES/XX



NEMESIS 6100

Load Cell, Closed loop
Fully automatic Rockwell/
Superficial Rockwell
(Brinell) hardness tester
with descending test head
& fixed workpiece position.
full color touchscreen
operation.
See brochure B19N6100/XX



NEMESIS 6200

Load Cell, Closed loop
Fully automatic Rockwell/
Superficial Rockwell (Brinell)
hardness tester with
descending test head & fixed
workpiece position, integrated
PC, Windows 10, WiFi, full
color 15" industrial capacitive
touchscreen.

Includes CNC motorized
X-Y stage, overview camera
and advanced software
(IMPRESSIONS™) for automatic
pattern testing and fixture
recognition.
See brochure B19N6200/XX



NEMESIS 9100RS

Load Cell, closed loop
Rockwell/Superficial Rockwell
Brinell hardness tester,
with integrated PC,
Windows 10, WiFi etc.
full color touchscreen.
See brochure B18N9100/XX

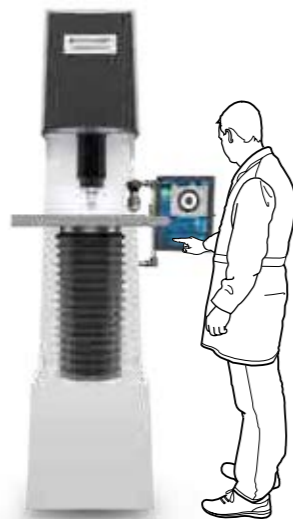

NEMESIS 9600RSB

Floor type, Load Cell,
closed loop.
Brinell, Rockwell/Superficial Rockwell
hardness tester
With motorized Z-axis & BIOS Brinell
Indent Optical Scanner
See brochure B19N9600/XX

Distributor :

CORPORATE HEAD OFFICE

INNOVATEST Europe BV

Manufacturing, Distribution & Service

Borgharenweg 140
6222 AA MAASTRICHT
The Netherlands

Phone: +31 43 3520060

Fax: +31 43 3631168

info@innovatest-europe.com

www.innovatest-europe.com

INNOVATEST Deutschland GmbH Sales & Service

Phone: +49 245 670 59 500
info@innovatest-deutschland.com
www.innovatest-deutschland.com

INNOVATEST France SARL Sales & Service

Phone: +33 1848 88038
info@innovatest-france.com
www.innovatest-france.com

INNOVATEST USA Company Sales & Service

Phone: +1 267 317 4300
info@innovatest-usa.com
www.innovatest-usa.com

INNOVATEST Japan K.K. Sales & Service

Phone: +81 3 6667 0554
info@innovatest-japan.com
www.innovatest-japan.com

INNOVATEST UK Ltd. Sales & Service

Phone: +44 121 274 0105
info@innovatest-uk.com
www.innovatest-uk.com

INNOVATEST Polska sp. z.o.o Sales & Service

Phone: +48 697 099 826
info@innovatest-polska.pl
www.innovatest-polska.pl

INNOVATEST Shanghai Co., Ltd. Sales & Service

Phone: +86 21 60906200
info@innovatest-shanghai.com
www.innovatest-shanghai.com

INNOVATEST South East Asia Sales & Service

Phone: +65 6451 1123
info@innovatest-singapore.com
www.innovatest-singapore.com