



MTS Acumen[®] Electrodynamic Test Systems

Delivering quieter, simpler and faster ways to get better data

be certain.



Low Maintenance



Industry-leading Performance



Small Footprint



Reduced Cost of Ownership



Operational Simplicity



Energy Efficient



Quiet Operation



Oil Free

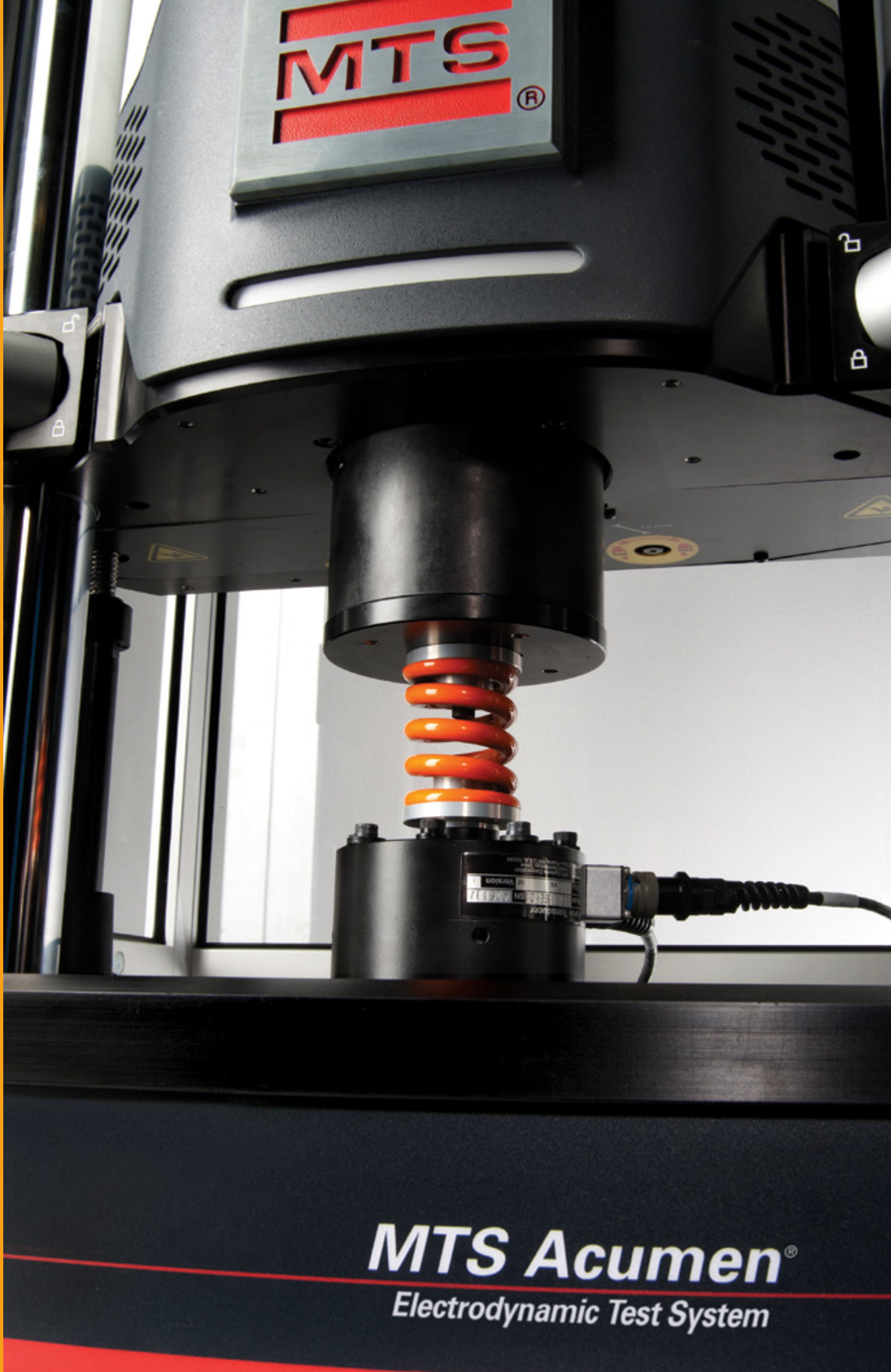

MTS Acumen[®]

Electrodynamic Test System

MTS Acumen Electrodynamic Test Systems

Available in force capacities up to 12 kN with options for torsion testing of components



Acumen 12
12 kN



Acumen 3
3 kN



Acumen 1
1 kN

Acumen 1H
1 kN



5

Comprehensive Testing Capabilities

MTS provides hardware, software and application expertise to support any testing requirements

Fatigue & Fracture

- » High-cycle fatigue to 100 Hz
- » From pre-cracking to fatigue crack growth
- » Low-cycle fatigue for high-temperature applications
- » File playback and spectrum loading to simulate automotive, aerospace and biomedical duty cycles
- » Fracture mode failure evaluation of full ductile-to-brittle material spectrum

Production Line Quality Control (QC)

- » Hardware and software configurations for in-line inspection and pass/fail quality control testing
- » Measure stiffness and other dynamic properties of viscoelastic materials, like the vibration isolation functionality used in automotive elastomer-based engine mounts
- » Smaller footprint than oil-based systems

DMA / Dynamic Characterization

- » Standard and high-force DMA, from -140C to 350C
- » Temperature and frequency sweeps
- » Assess dynamic properties as a function of fatigue
- » Tension, compression, bending, shear, and fully-reversed double cantilever
- » Modulus characterization down to 0.2 N peak-to-peak
- » Master Curves for product life evaluation

Tension / Compression

- » Ultimate strength of materials and components
- » Determine strain rate sensitivity
- » Controlled buckling failure
- » Creep and stress relaxation
- » Hold and pulse tests of products with buttons and switches
- » Pull and shear tests (common for adhesives and films)

Torsion

- » Unprecedented versatility (speed, angular displacement, number of cycles, continuous rotation, etc.)
- » Accessory versatility accommodates bone screws, fine wire, electronics, pill bottles, laminate shearing, biological tissue, etc.

Low-force Testing

- » Microscale testing (milli-Newtons)
- » Combined low-force and low-torque testing
- » Low-torque testing of very small components
- » Tactile-feel load measurement in displacement control
- » Simulate a physiological pressure range (80-120 mmHg)

Equipped with a Bionix® EnviroBath, MTS Acumen test systems enable efficient, accurate testing of biomedical and general material specimens in fluids heated to body temperature.



Accessories for Dynamic & Static Testing

A sample of the many accessories available for Acumen systems

Grips & Fixtures



Scissors Action Grip



Thumb Screw Grips



Spring Action Grip



645 Pneumatic Grips



Shear Fixtures



Tension/Compression Grips



Cam-action Tensile Grips

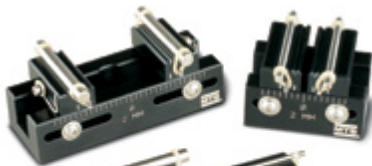

Bend Fixtures



Compression Platens

Environmental



Environmental Chambers

Bionix EnviroBath

7

Accessories



Alignment Fixture



XY table



Pinned Attachment Kit
(threaded also available)

Load/Strain Measurement



661 Load Cell

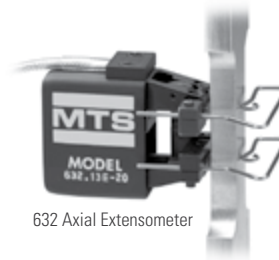

632 Axial Extensometer

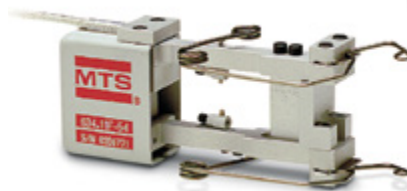

634 Axial Extensometer

Test Productivity

Industry leading MTS TestSuite™ software simplifies test setup and data collection, display, and analysis



Customized test templates or guided test setup

- » Easy – Standard test templates
- » Flexible – Fast tailoring of standard templates
- » Powerful – Detailed implementation of specific testing techniques

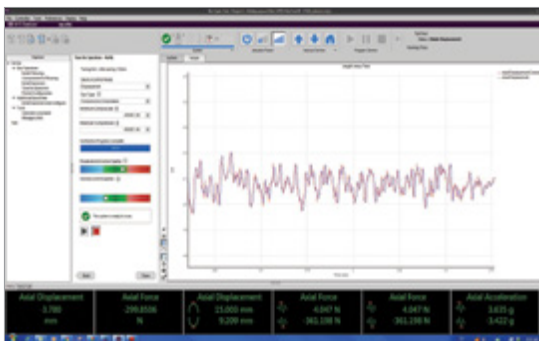

Auto-tuning capability

- » Increased usability without compromising capabilities
- » Auto-tuning allows software to measure and enter specimen parameters
- » No need to enter stiffness values
- » Raw control loop parameter access for advanced users
- » Axial and torsional auto-tuning

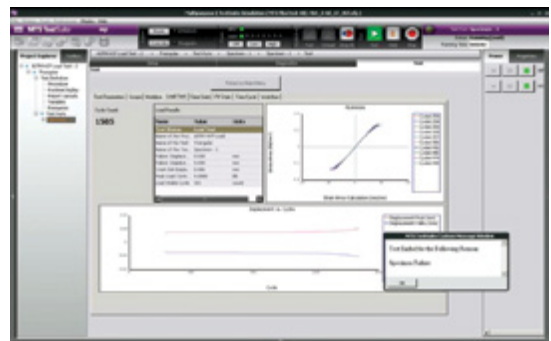

Generating & distributing data

- » Full-function oscilloscope and meters to show real-time display of parameters (velocity, hysteresis, cyclic data)
- » Real-time display of calculated results; no need for test to finish and perform post-test analysis
- » Quick save of displayed data for real-time evaluation of long-term tests
- » Choose from a variety of application programs tailored to specific tests and standards

Technical Highlights

Features of the Acumen platform focus on testing flexibility and safety

Test setup designed with safeguards

- » System control mode during test setup and tuning is stable, helping prevent pretest sample or system damage
- » Test limit settings are accomplished easily and quickly with mouse-controlled adjustments to visually simple graphics
- » Visual directional control graphics ensure error-free test parameter settings and modifications
- » Guided and automated test setup processes facilitate creating new or modifying existing test protocols

Controlled stop feature enhances system stability

- » Establishes the desired end-of-test specimen condition eliminating excessive or undesirable specimen damage
- » Enables quick recovery and return to intended test conditions
- » Ensures actuator remains safely controlled and predictable when test limits are reached
- » Safe and reliable limit actions increase confidence and efficiency during test setup

Mounting hardware & sensor options provide convenience & flexibility

- » Easily and quickly transition the system load cell between the base and the actuator
- » Standard T-Slot base with common functionality across frames
- » Common threaded interface with pilot features on the load cell, actuator, and base plate all provide reliable and consistent alignment
- » Optional threaded attachment kits for leveraging a wide array of MTS and customer grips and fixtures
- » Several system and tandem load cell options and also an optional high performance Advanced Dynamic Response (ADR) sensor for very low-force testing of dynamic loads (as low as 0.2 N peak-to-peak)

Auto-tune methodology - uniquely MTS

- » Accurate electrodynamic system tuning, accomplished with patent-pending software algorithms for comprehensive specimen characterization
- » All system control modes are tuned simultaneously in one simple step, for both axial & torsional testing
- » Verification feature measures quality of tuning
- » Tuning options for even the most challenging samples

System-level engineering delivers added precision & accuracy

- » Sturdy design increases system stiffness
- » Acceleration compensation techniques deliver unparalleled closed loop performance
- » High resolution linear encoder for precise crosshead measurements
- » Alignment fixtures are available
- » Engineered options for complex Dynamic Mechanical Analysis (DMA) testing through glass transition, including Master Curves



Acumen 12



Acumen 1H

Scalable Controllers & Remote Monitoring Solutions

Best-in-class multi-station control and remote monitoring solutions for labs with multiple systems

- » Industry-leading control performance enabled by lowest latency
- » Advanced control algorithms and compensators achieve unparalleled testing accuracy
- » Mezzanine card-based design enables future expandability
- » Four chassis sizes provide the right level of scalability
- » Versatile and easy to reconfigure as your testing needs change
- » Independent safety interlock chains for each station ensure the right response to limit trips
- » Large selection of modules to support a wide variety of sensors and equipment
- » Support for Transducer Electronic Data Sheets (TEDS)

** MTS Echo® Intelligent Lab offers cloud-based or local network solutions to monitor test status and equipment health*

11



Torsion Testing

Acumen systems offer higher speeds, higher torque and more continuous rotation

Applications

- » Biomechanics studies of orthopaedic systems and implants
- » Torsional strength and stiffness characterization of bone screws and small scale medical devices, fine wires, fibers, etc,
- » Wound healing (bone) studies that define an exercise and drug regimen to expedite healing outcome
- » Complex medical packaging evaluation, including childproof pill bottles that are designed to be easier for seniors to open
- » Torsional DMA studies in addition to traditional axial or lap-shear configuration
- » Torsional shear performance of adhesives
- » Support and validate FEA or materials models that have torsional elements

Horizontal Testing

Sometimes testing is more practical or application appropriate when the specimen is positioned horizontally

When to consider horizontal

Testing setup better suited or practical in a horizontal position:

- » Specimen weight needs to be supported by a fluid medium (films, skin, tissue)
- » Where sealing of physiological environments is not practical in the vertical orientation
- » Placement of confocal microscopes or other imaging devices can only operate horizontally
- » Specimens are not sensitive to test orientation

Applications

- » Microelectronics performance evaluations of PCBs, flexible circuits, solder, buttons/switches/connectors, and packaging materials and components, integrated circuits, etc.
- » Simulation of thermal cycling of micro-circuits and in-use loading
- » Properties testing of biomaterials and biomedical devices in 37C biologic fluid environments
- » Dynamic pressure simulation of physiologic conditions
- » Polymers, thin films and foils, fibers/fiber bundles/fine wires, sutures testing for basic properties
- » Basic materials research and support of/validation of analytical models
- » Strength of adhesives, glues, connectors, etc.



Acumen 1H

Lab Productivity

MTS offers the products, engineering support and application expertise to maximize lab efficiency



Optimize your test system readiness

- » Hardware and software maintenance programs
- » Spares programs, extended warranties
- » Accredited calibration services & system alignment
- » Remote test monitoring with MTS Echo® products
- » Predictive maintenance programs
- » Lab facility efficiency audits

13



Maximize your testing efficiency

- » Hardware and software training classes at MTS offices or at your facility
- » Material and application consulting
- » Advanced test design software training
- » Custom test template design services
- » Local service engineers
- » Lab process efficiency audits

Tailor your lab's data management requirements

MTS' solutions are designed to fit seamlessly into the overall laboratory LIMS ecosystem, and MTS consultants are available to customize data integration.

- » Customize your test system data output
- » Automate data flow between the test machine & LIMS systems or material databases
- » Leverage MTS system consultants for system integration challenges

Specifications

Load Frame Specifications ¹	Diagram Detail	MODEL		
		Acumen 1	Acumen 1 A/T	Acumen 1H
Dynamic force²		1250 N (281 lbf)	1250 N (281 lbf)	1250 N (281 lbf)
Static force²		850 N (191 lbf)	850 N (191 lbf)	850 N (191 lbf)
Dynamic torque rating		–	±15 Nm (132 in-lb)	–
Static torque rating		–	±11 Nm (97 in-lb)	–
Actuator dynamic stroke		70 mm (2.75 in)	70 mm (2.75 in)	70 mm (2.75 in)
Angular displacement		–	±135° ±20 revolutions 0.001 rpm - 100 rpm continuous rotation to 350 rpm	–
Dynamic performance		≤100 Hz	≤100 Hz	≤100 Hz
Minimum test space height³	A	26 mm (1.02 in)	26 mm (1.02 in)	26 mm (1.02 in)
Maximum test space height⁴	A	603 mm (23.74 in)	392 mm (15.43 in)	603 mm (23.74 in)
Working height⁵	B	133 mm (5.24 in)	133 mm (5.24 in)	133 mm (5.24 in)
Test space width (measured between columns)	C	375 mm (14.76 in)	375 mm (14.76 in)	–
Base plate design		T-Slot (industry standard: 8 mm)	T-Slot (industry standard: 8 mm)	T-Slot (industry standard: 8 mm)
Column diameter	D	63.5 mm (2.5 in)	63.5 mm (2.5 in)	–
Frame footprint width	E	550 mm (21.62 in)	550 mm (21.62 in)	1561 mm (61.5 in)
Frame footprint depth⁶	F	485 mm (19.09 in)	485 mm (19.09 in)	535 mm (21.1 in)
Overall width⁶ (with frame-mounted controller)	G	679 mm (26.73 in)	679 mm (26.73 in)	679 mm (26.73 in)
Overall height⁷	H	1511 mm (59.49 in)	1511 mm (59.49 in)	544 mm (21.4 in)
Weight		159 kg (350 lb)	201 kg (443 lb)	163 kg (360 lb)
Noise level - typical⁸		47 dbA	47 dbA	47 dbA
Noise level - maximum⁸		69 dbA	69 dbA	69 dbA
Mounting		Tabletop: Vertical	Tabletop: Vertical	Tabletop: Horizontal
Standard load cell		1.5 kN Accel Comp	1.5 kN Accel Comp	1.5 kN Accel Comp
Operating temperature		+5C° to +40C°	+5C° to +40C°	+5C° to +40C°
Cooling		Automated forced air	Automated forced air	Automated forced air
Electrical requirements⁹	Voltage - VAC Frequency - Hz Current - Amps Phase	100-120 (200-240) 50-60 7 (4) Single	200-240 50-60 20 Single	100-120 (200-240) 50-60 7 (4) Single

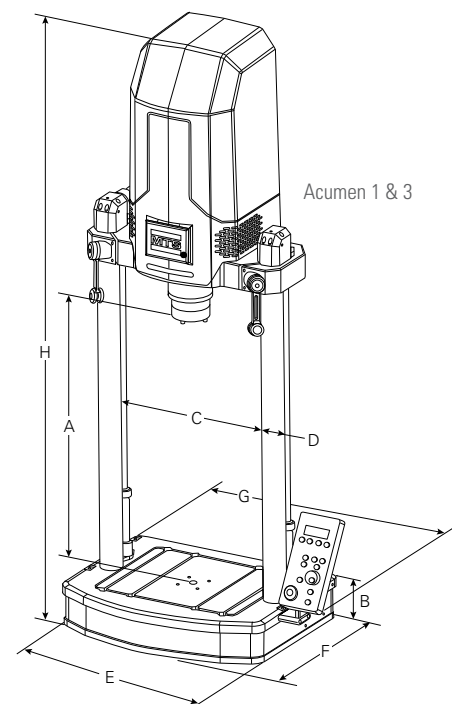
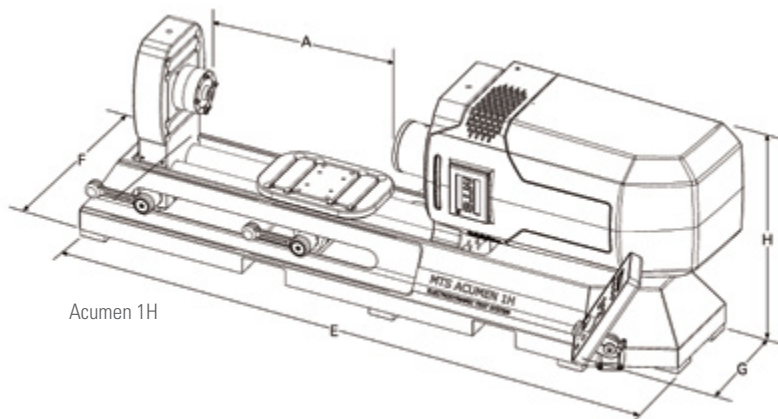

Load Frame Specifications ¹	Diagram Detail	MODEL			
		Acumen 3	Acumen 3 A/T	Acumen 12	Acumen 12 A/T
Dynamic force²		3000 N (670 lbf)	3000 N (670 lbf)	12000 N (2697 lbf)	12000 N (2697 lbf)
Static force²		2000 N (450 lbf)	2000 N (450 lbf)	8500 N (1910 lbf)	8500 N (1910 lbf)
Dynamic torque rating		–	±30 Nm (265 in-lb)	–	±120 Nm (1056 in-lb)
Static torque rating		–	±21 Nm (185 in-lb)	–	±84.8 Nm (746 in-lb)
Actuator dynamic stroke		70 mm (2.75 in)	70 mm (2.75 in)	70 mm (2.75 in)	70 mm (2.75 in)
Angular displacement		–	±135° ±20 revolutions 0.001 rpm - 100 rpm continuous rotation to 350 rpm	–	±135° ±20 revolutions 0.001 rpm - 100 rpm continuous rotation to 100 rpm
Dynamic performance		≤100 Hz	≤100 Hz	≤100 Hz	≤100 Hz
Minimum test space height³	A	26 mm (1.02 in)	0 mm (0.00 in)	55 mm (2.17 in)	0 mm (0.00 in)
Maximum test space height⁴	A	819 mm (32.24 in)	603 mm (23.74 in)	985 mm (38.8 in)	810 mm (31.9 in)
Working height⁵	B	133 mm (5.24 in)	133 mm (5.24 in)	815 mm (32.1 in)	815 mm (32.1 in)
Test space width (measured between columns)	C	460 mm (18.11 in)	460 mm (18.11 in)	460 mm (18.11 in)	460 mm (18.11 in)
Base plate design		T-Slot (industry standard: 8 mm)	T-Slot (industry standard: 8 mm)	T-Slot (industry standard: 14 mm)	T-Slot (industry standard: 14 mm)
Column diameter	D	63.5 mm (2.5 in)	63.5 mm (2.5 in)	76.2 mm (3 in)	76.2 mm (3 in)
Frame footprint width	E	634 mm (24.96 in)	634 mm (24.96 in)	651 mm (25.6 in)	651 mm (25.6 in)
Frame footprint depth⁶	F	501 mm (19.72 in)	501 mm (19.72 in)	817 mm (32.2 in)	817 mm (32.2 in)
Overall width⁶ (with frame-mounted controller)	G	764 mm (30.08 in)	764 mm (30.08 in)	805 mm (31.7 in)	805 mm (31.7 in)
Overall height⁷	H	1726 mm (67.95 in)	1726 mm (67.95 in)	2810 mm (110.7 in)	2810 mm (110.7 in)
Weight		188 kg (415 lb)	230 kg (507 lb)	953 kg (2100 lb)	1043 kg (2300 lb)
Noise level - typical⁸		47 dbA	47 dbA	62	62
Noise level - maximum⁸		69 dbA	69 dbA	78	78
Mounting		Tabletop: Vertical	Tabletop: Vertical	Floor: Vertical	Floor: Vertical
Standard load cell		3 kN Accel Comp	3 kN Accel Comp	12 kN Accel Comp	12 kN Accel Comp
Operating temperature		+5C° to +40C°	+5C° to +40C°	+5C° to +40C°	+5C° to +40C°
Cooling		Automated forced air	Automated forced air	Automated forced air & self contained water cooled	Automated forced air & self contained water cooled
Electrical requirements⁹	Voltage - VAC Frequency - Hz Current - Amps Phase	200-240 50 - 60 10 Single	200-240 50 - 60 20 Single	200-240 50 - 60 38 Single	200-240 50 - 60 38 Single

- Specifications subject to change without notice.
- Verifiable with MTS compression spring test. Performance may vary depending on test type, test set-up, frequency, specimen, environment and other factors.
- Assumes standard system load cell installed, crosshead fully lowered and actuator fully extended to end of the dynamic stroke.
- Assumes standard system load cell installed, crosshead fully raised and actuator fully retracted to end of the dynamic stroke.
- From table to top of work surface; without optional isolation pads.
- For systems with optional test area enclosure, add 98 mm (3.8 in.) to dimension F and 45 mm (1.8 in) to dimension G for overall system dimensions.
- Measured with crosshead fully raised, without optional isolation pad.
- Typical usage at 1 m, free field. Noise level varies depending upon test type, specimen, environment and other factors.
- Acumen 1 current rated at 100 (200) VAC. Acumen 3 current rated at 200 VAC.

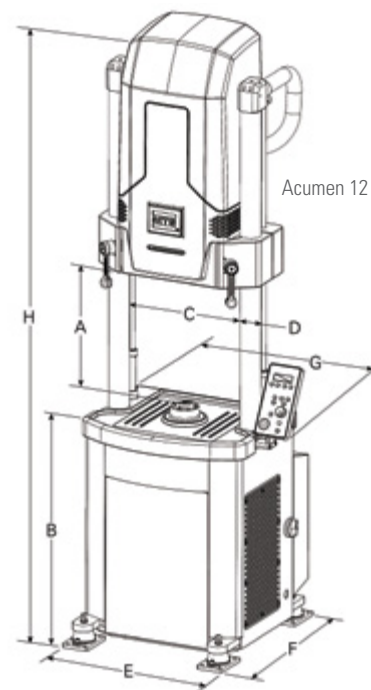

Performance Curves

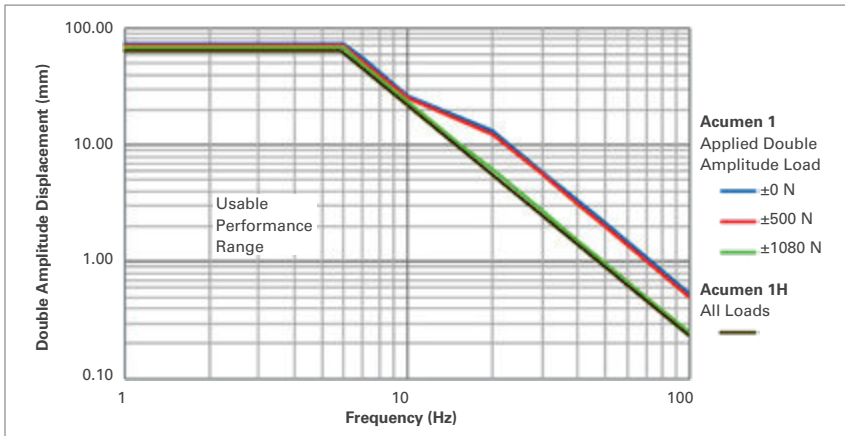

Acumen 1 / Acumen 1H
Axial Dynamic Performance

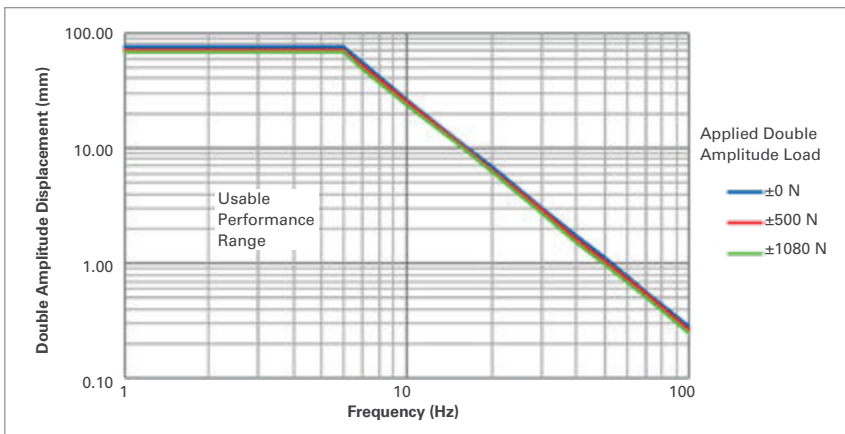

Acumen 1 A/T
Axial Dynamic Performance

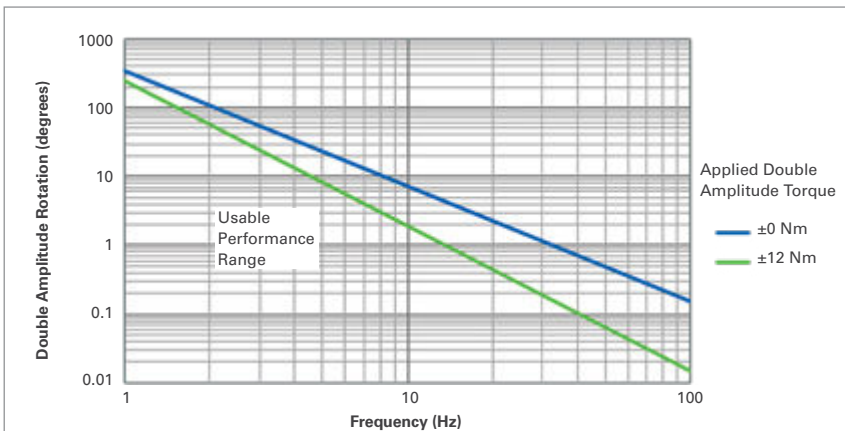

Acumen 1 A/T
Torsional Dynamic Performance

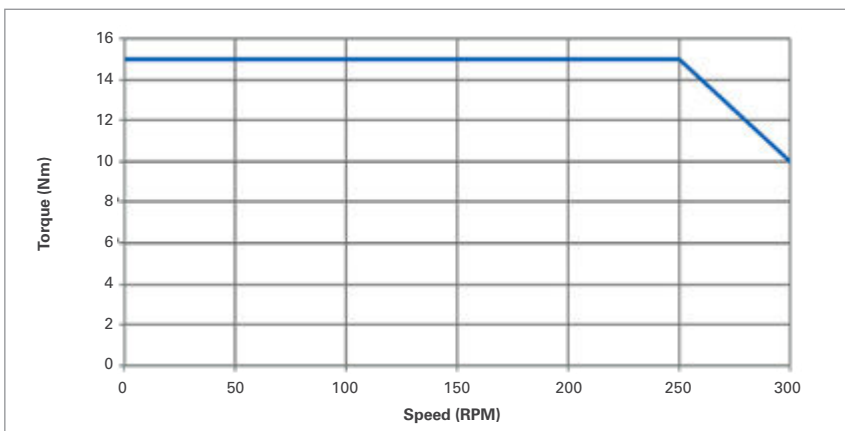

Acumen 1 A/T
Speed vs. Torque

Performance Curves

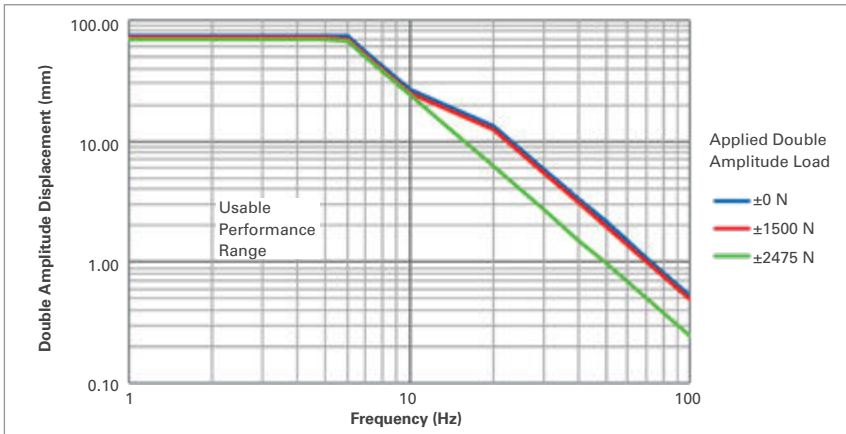

Acumen 3
Axial Dynamic Performance

17

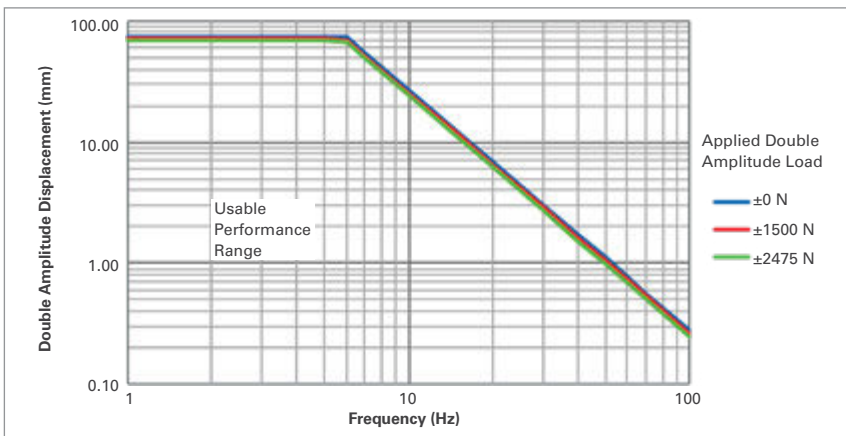

Acumen 3 A/T
Axial Dynamic Performance

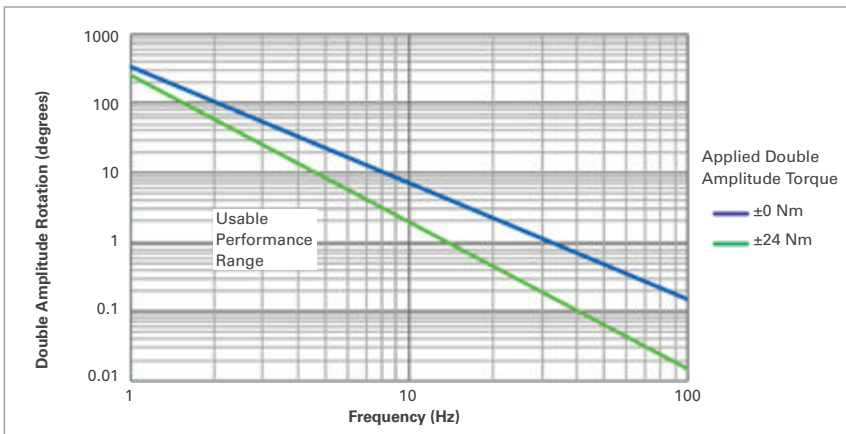

Acumen 3 A/T
Torsional Dynamic Performance

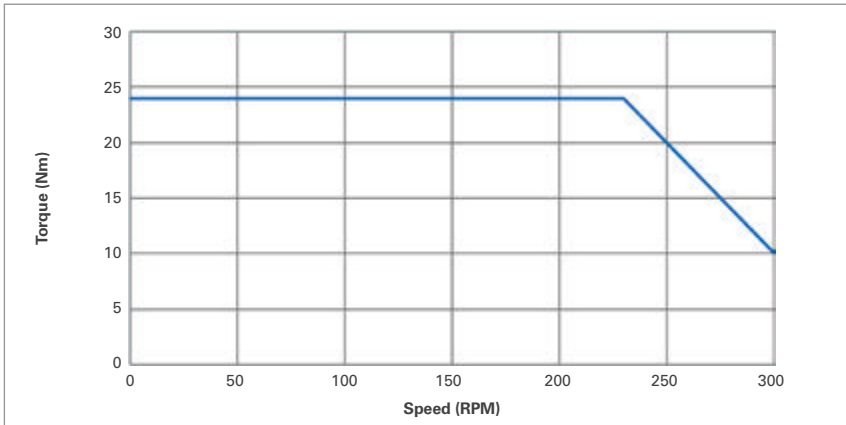

Acumen 3 A/T
Speed vs. Torque

Performance Curves

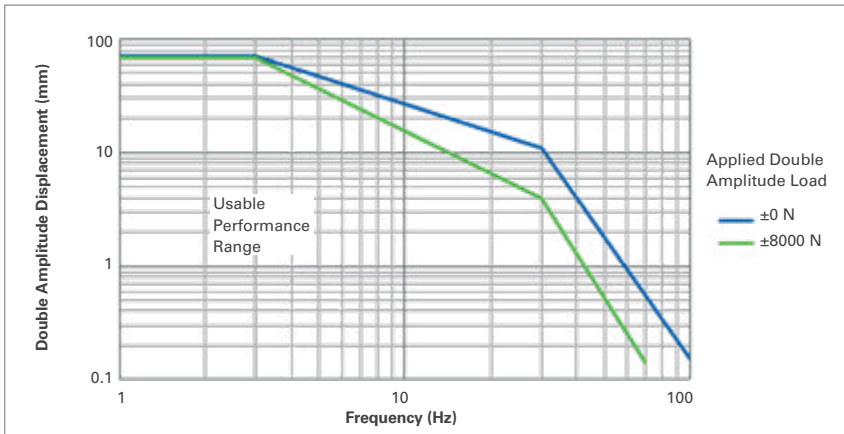

Acumen 12
Axial Dynamic Performance

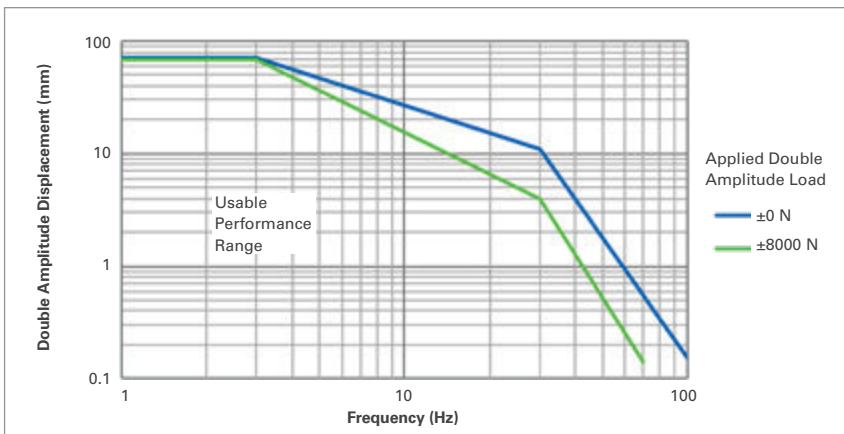

Acumen 12 A/T
Axial Dynamic Performance

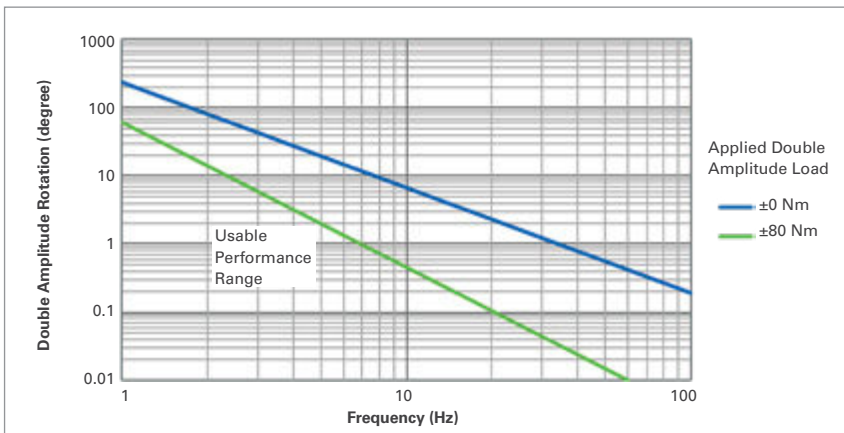

Acumen 12 A/T
Torsional Dynamic Performance

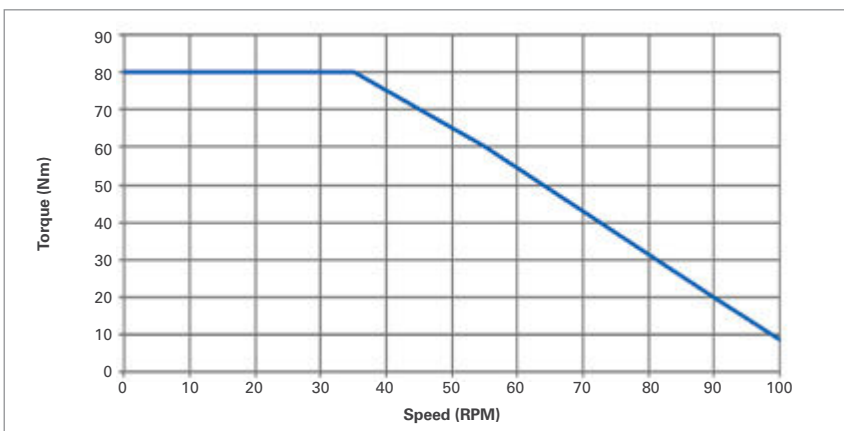

Acumen 12 A/T
Speed vs. Torque

Common ASTM / ISO Standards

MTS supports testing to both industry and proprietary test standards

Bio / Medical Devices

- » ISO 14801 Dynamic Fatigue for Endosseous Dental Implants
- » ISO 6475 Implants for Surgery: Metallic Bone Screws
- » ASTM F1717 Spinal Implant Constructs in a Vertebrectomy Model
- » ASTM F2077 Test Methods for Intervertebral Body Fusion Devices
- » ISO 7206 / ASTM 1440 Uniaxial Endurance of Stemmed Femoral Components
- » ASTM F543 Torsional Testing of Metallic Medical Bone Screws
- » ASTM F1800 and ISO 14879 Fatigue Testing of Metal Tibial Tray Component for Total Knee Joint Replacements
- » ASTM F3140-17 Standard Test Method for Cyclic Fatigue Testing of Metal Tibial Tray Components of Unicondylar Knee Joint Replacements

DMA / Dynamic Characterization

- » ASTM D7028 Glass Transition Temperature (DMA T_g) of Polymer Matrix Composites by Dynamic Mechanical Analysis (DMA)
- » ASTM D5992 Dynamic Testing of Vulcanized Rubber (Elastomer) and Rubber-Like Materials
- » ASTM D5023 Dynamic Mechanical Properties (DMA) of Plastics in Flexure (Three-Point Bending)
- » ASTM D5024 Dynamic Mechanical Properties (DMA) of Plastics in Compression
- » ASTM D5026 Dynamic Mechanical Properties (DMA) of Plastics in Tension
- » ASTM D5418 Dynamic Mechanical Properties (DMA) of Plastics in Flexure (Dual Cantilever Beam)
- » ISO 6721-4 and -5 Dynamic Mechanical Properties (DMA) Tensile Vibration; Flexural Vibration

Fatigue & Fracture

- » ISO 1099 Metallic Materials - Fatigue Testing - Axial Force Controlled Method
- » ASTM 466-96 Conducting Force Controlled Constant Amplitude Axial Fatigue Tests
- » ASTM 468-90 Presentation of Constant Amplitude Test Results
- » ASTM E606, D3479, E466: Low-Cycle and High- Fatigue (Advanced and High Temperature)
- » ASTM E2368, EUR 22281 EN: Thermomechanical Fatigue (TMF)
- » ASTM E647 Fatigue Crack Growth (Clip gages and Direct Current Potential Drop (DCPD))
- » ASTM E399, E1290 and E1820: Fracture Toughness (K_{Ic}, Crack Tip Opening Displacement (CTOD), J_{Ic}- CTOD)
- » ASTM 399-17 Linear-Elastic Plane-Strain Fracture Toughness K_{Ic} of Metallic Materials

Tension / Compression

- » ISO 6892 Tensile Testing of Metallic Materials at Ambient Temperature
- » ASTM D412 Tensile Properties of Vulcanized Rubber and Thermoplastic Elastomers
- » ASTM D882 Tensile Properties of Thin Film/Plastic Sheeting
- » ASTM 527-2 Tensile Properties of Moulding and Extrusion Plastics
- » ASTM 527-3 Tensile Properties of Plastic Films and Sheets

Torsion

- » ASTM F543 Torsional Testing of Metallic medical bone screws
- » ISO 7800 Metal Wire Torsion Testing
- » ASTM A938 Torsional Test of Wire
- » ASTM D1043 Torsion of Plastics Testing
- » ASTM D5279 Thermoset and Thermoplastic Dynamic Torsion Testing
- » ASTM F383 Static Bend and Torsion Testing of Intramedullary Rods
- » ISO 5835/6475/9268 Bone Screw Torsion Test Methods
- » ISO 80369-1 Axial-Torsion Luer Connector Testing

Regional Business Centers

THE AMERICAS

MTS Systems Corporation

14000 Technology Drive
Eden Prairie, MN 55344-2290
USA

Telephone: 952-937-4000
Toll Free: 800-328-2255
Fax: 952-937-4515
E-mail: info@mts.com
Internet: www.mts.com

EUROPE

MTS Systems France

BAT EXA 16
16/18 rue Eugène Dupuis
94046 Créteil Cedex

France

Telephone: +33-(0)1-58 43 90 00
Fax: +33-(0)1-58 43 90 01
E-mail: contact.france@mts.com

MTS Systems GmbH

Hohentwielsteig 3
14163 Berlin

Germany

Telephone: +49-(0)30 81002-0
Fax: +49-(0)30 81002-100
E-mail: euroinfo@mts.com

MTS Systems S.R.L. a socio unico

Strada Pianezza 289
10151 Torino

Italy

Telephone: +39-(0)11 45175 11 sel. pass.
Fax: +39-(0)11 45175 00-01
E-mail: mtstorino@mts.com

MTS Systems Norden AB

Datavägen 37b
SE-436 32 Askim

Sweden

Telephone: +46-(0)31-68 69 99
Fax: +46-(0)31-68 69 80
E-mail: norden@mts.com

MTS Systems Ltd. UK

40 Alan Turing Road
Surrey Research Park
Guildford
Surrey
GU2 7YF

United Kingdom

Telephone: +44-(0)1483-533731
Fax: +44-(0)1483-504564
E-mail: mts-sales@mts.com

ASIA/PACIFIC

MTS Japan Ltd.

ArcaCentral Bldg. 8F
1-2-1 Kinshi, Sumida-ku
Tokyo 130-0013

Japan

Telephone: 81-3-6658-0901
Fax: 81-3-6658-0904
E-mail: mts-j-info@mts.com

MTS Korea, Inc.

4th F., ATEC Tower, 289,
Pankyo-ro, Bundang-gu
Seongnam-si
Gyeonggi-do 13488,

Korea

Telephone: 82-31-728-1600
Fax: 82-31-728-1699
E-mail: mtsk-info@mts.com

MTS China Hechuan Office

Room 703 Building #B,
Venture International Park,
No. 2679 Hechuan Road,
Minhang District,
Shanghai 201103,

P.R.China

Telephone: +86-21-5427 1122
Fax: +86-21-6495 6330
E-mail: info@mtschina.com

MTS Testing Solutions Pvt Ltd.

Unit No. 201 & 202, Second Floor
Donata Radiance,
Krishna Nagar Industrial Layout,
Koramangala, Bangalore - 560029
Karnataka, India
Telephone: + 91 80 46254100
Email: mts.india@mts.com



MTS Systems Corporation

14000 Technology Drive
Eden Prairie, MN 55344-2290 USA

ISO 9001 Certified QMS
<http://www.mts.com>

Specifications subject to change without notice.

MTS, MTS Acumen, MTS Echo and MTS FlexTest are registered trademarks and MTS TestSuite Multipurpose are trademarks of MTS Systems Corporation in the United States. These trademarks may be protected in other countries. RTM No. 211177.

All other trademarks are property of their respective owners.

©2019 MTS Systems Corporation
100-257-545d Acumen • Printed in U.S.A. • 03/19